

PRINCE OF SONGKLA UNIVERSITY
FACULTY OF ENGINEERING

Examination : Final - Session 2

Year : 2002

Date : 28 February 2003

Time : 9.00-12.00

Subject : 240-233 Principles of Digital Systems

Room :

NOTE

- There are 2 parts, 6 questions. Answer all questions
- All questions are of different values.
- Calculator, textbooks and hand-out are prohibited.
- Every answer must be clear and show how to get the answer.
- All answers must be given in ink.
- Unless otherwise indicated, pencils should only be used for graphical work.

Student ID : _____ Name : _____ Section : _____

Question	Points	
1	8	
2	3	
3	3	
4	6	
5	5	
6	20	
Total	45	

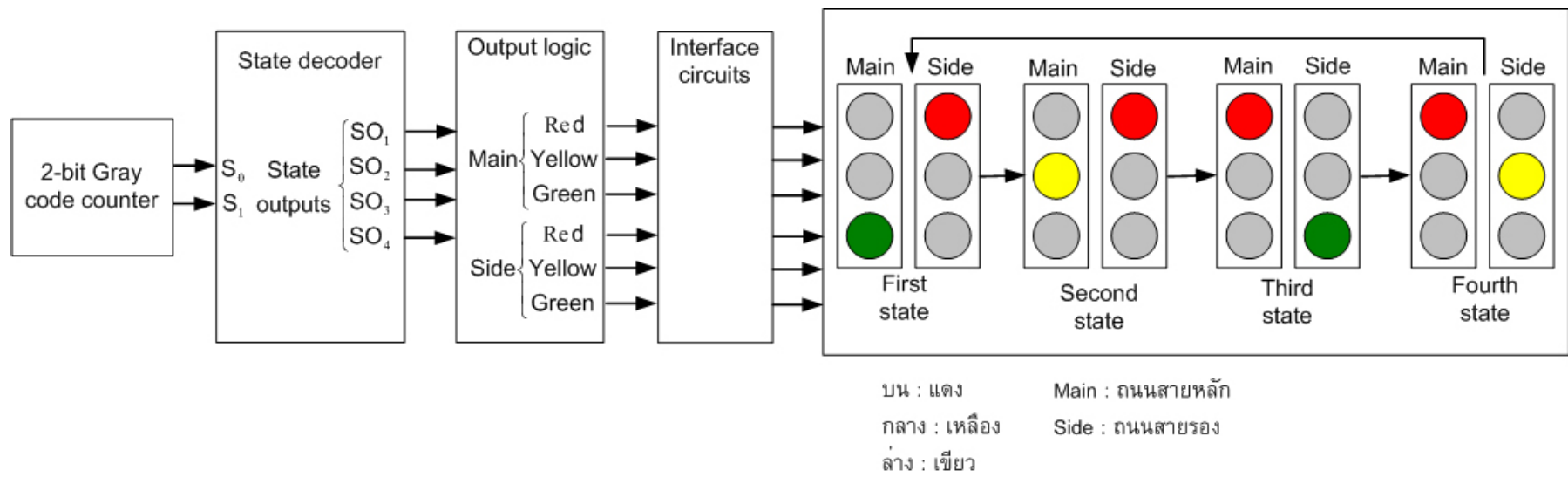

รูปที่ 3 แสดงระบบควบคุมสัญญาณไฟจราจร

Appendix

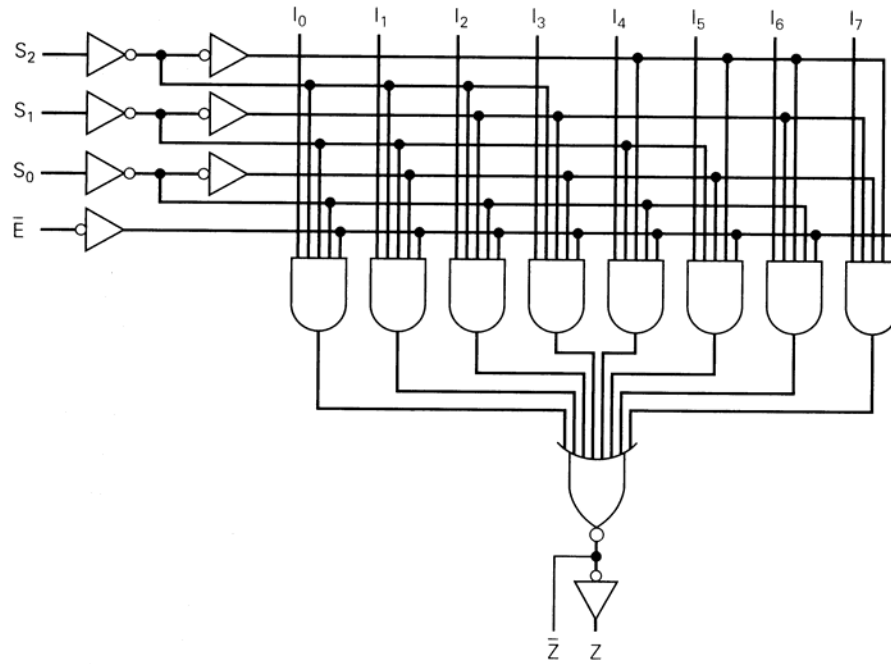

(a)

Inputs				Outputs	
\bar{E}	S_2	S_1	S_0	\bar{Z}	Z
H	X	X	X	H	L
L	L	L	L	\bar{I}_0	I_0
L	L	L	H	\bar{I}_1	I_1
L	L	H	L	\bar{I}_2	I_2
L	L	H	H	\bar{I}_3	I_3
L	H	L	L	\bar{I}_4	I_4
L	H	L	H	\bar{I}_5	I_5
L	H	H	L	\bar{I}_6	I_6
L	H	H	H	\bar{I}_7	I_7

(b)

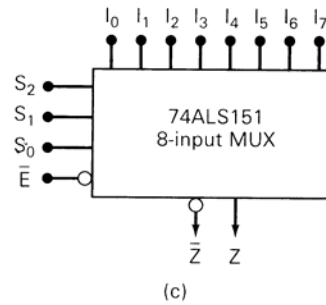

(c)

74LS151