



PRINCE OF SONGKLA UNIVERSITY
FACULTY OF ENGINEERING

Final Examination: Semester I

Date: 4 October 2006

Subject: 240-543 Broadband Integrated Networks

Academic Year: 2006

Time: 13.30-16.30

Room: R-300

- In this exam paper, there are four questions,
- All notes and books are not allowed,
- Answers could be either in Thai or English,
- Only un-programmable calculator is allowed,
- Try to attempt answering all questions.

1. Figure 1, 2, and 3 show the scenario of how new AAL-2 multiplexes several voice traffic into one channel (one virtual channel (VC) in ATM context). Each 64 kbps voice channel is compressed by using the CS-ACELP scheme with silent suppression. During silent period there is no data to send. New AAL-2 is suitable for compressed wireline telephony, wireless telephony, and wireless data.
 - a. Please describe how this scenario works (please refer to given information from **Figure 1 to Figure 3**). (15 Marks)
 - b. What is the overhead of this scheme (show your calculation) (5 Marks)

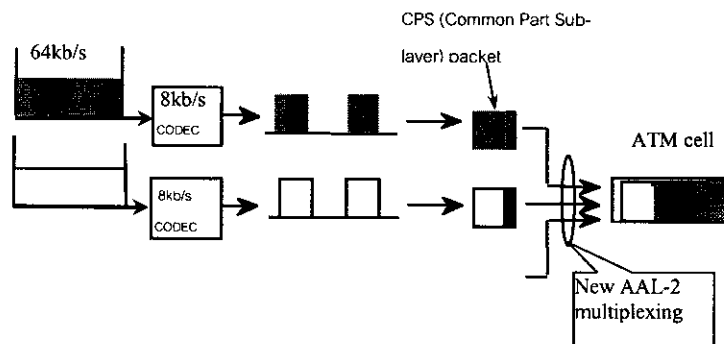

Figure 1 Voice and telephony multiplexing over ATM using AAL2.

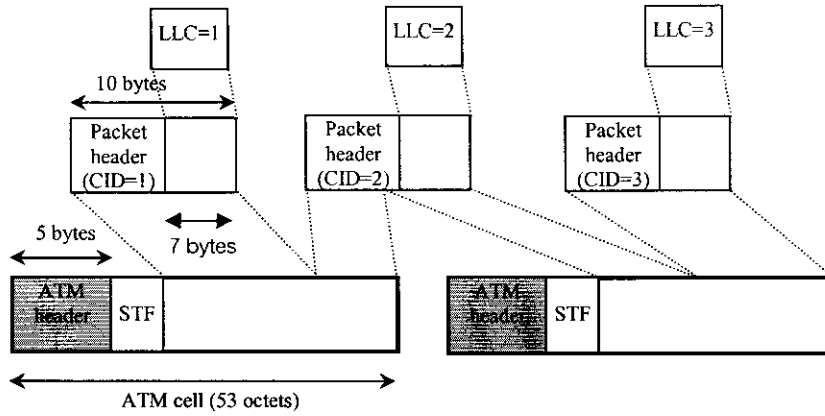

Figure 2 ATM cell structure for supporting AAL-2 multiplexer

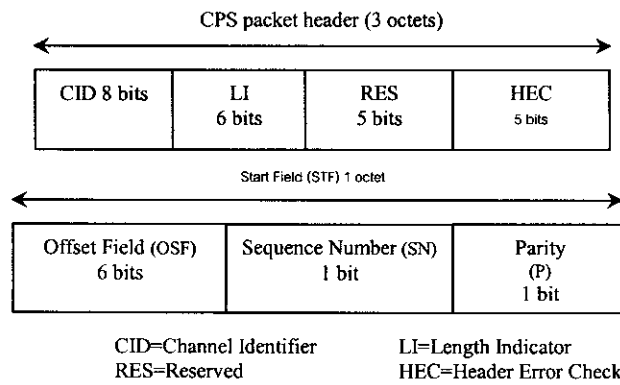

Figure 3 Structure of packet header and start filed.

2. Leaky bucket

2.1 Leaky bucket without data buffer Scheme (10 Marks)

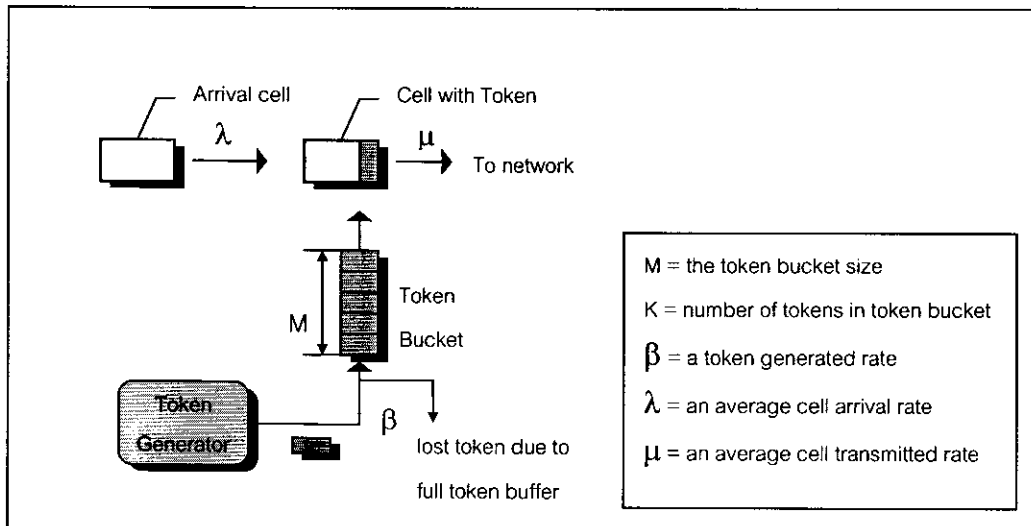

Figure 4 Buffered leaky bucket without data buffer Scheme

Figure 4 shows a *leaky bucket without data buffer or unbuffered leaky bucket without data buffer scheme*. Tokens are generated with rate β and stored in the token bucket which has finite capacity M . If the token bucket is full ($\beta T \geq M$) then next token is discarded. An arrival cell is placed with a token from the token bucket if the token bucket is not empty otherwise the cell is discarded.

The below figure show arrival cell and token in leaky budget, please draw transmitted cells in the given time slots. Please also state clearly that what cell numbers will be discarded

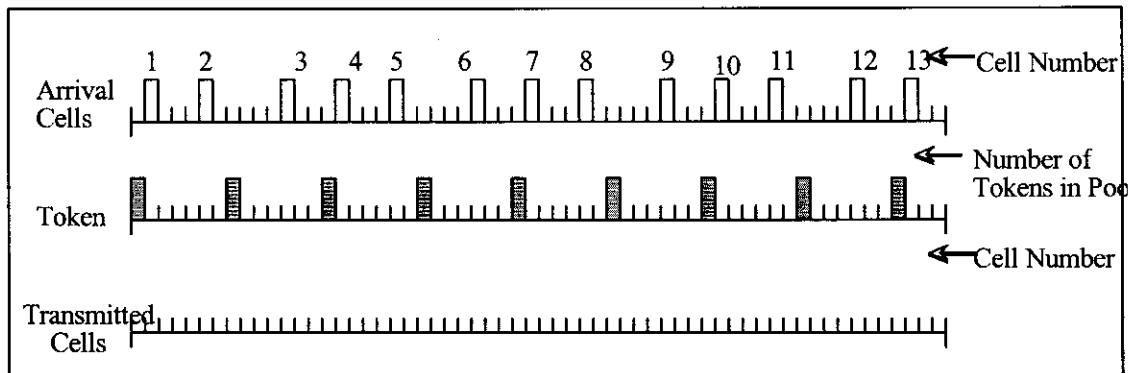

Figure 5 for question 2.1

2.2 Leaky Bucket with data buffer (10 Marks)

Figure 6 shows *leaky bucket with data buffer or buffered leaky bucket with data buffer scheme* [A01][A06]. Tokens are generated with rate β and stored in the token bucket which has finite capacity M . If the token bucket is full ($\beta T \geq M$) then next token is discarded. An arrival cell from the data buffer is placed and transmitted with μ rate with a token from the token bucket if the token bucket is not empty otherwise the cell is stored in the data buffer which has a finite capacity M if it is not full ($N < M$) and discarded when it is full ($N \geq M$).

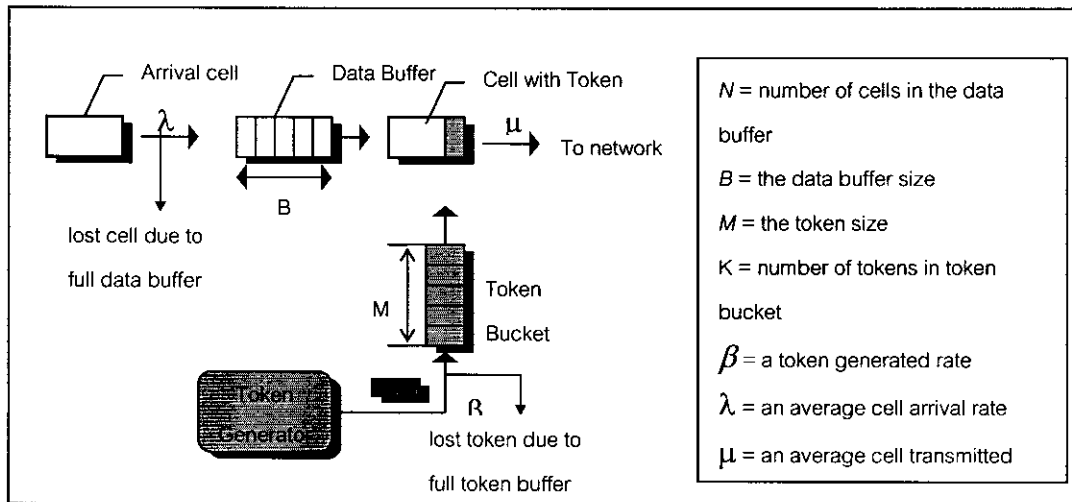

Figure 6 Leaky Bucket with data buffer

The below figure show arrival cell and token in leaky bucket, please draw transmitted cells in the given time slots. Please also state clearly that what cell numbers will be discarded.

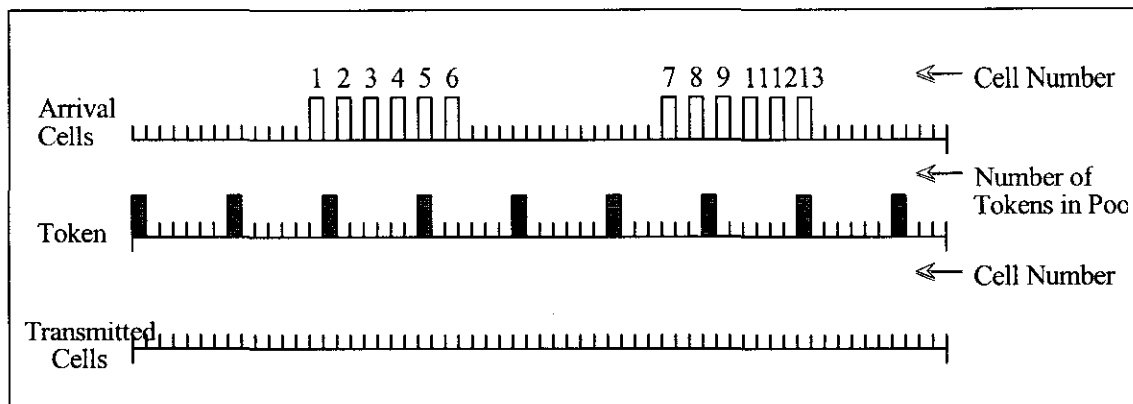

Figure 7 For question 2.2

3 (20 Marks) The following steps are the rule for worst case allocation for VBR VCs:

1. Assume that all connections are compliant with $GCRA(1/PCR,0)$ and $GCRA(1/SCR,\tau_s)$,
2. Determine N , the maximum number of source $N \times SCR \leq PCR$,
3. Find out the worst case for one source with $MBS = \text{integer} [1 + \tau_s / (1/SCR - 1/PCR)]$,
4. Assume that all sources are synchronised and transmit their worst case traffic,
5. Find the buffer size to avoid any overflow $Req_Buf = (N - PCR_0 / PCR) \times MBS$,
6. Compute the maximum delay $D \leq Req_Buf / PCR_0$.

In our system the out-going link bandwidth is 155 Mbps. There are four types of sources tested in out system with the following source traffic parameters:



Type A: $MBS = 200$ cells, $SCR = 5,000$ cells/sec, $PCR = 25$ MBPS

Type B: $MBS = 200$ cells, $SCR = 5,000$ cells/sec, $PCR = 155$ MBPS

Type C: $MBS = 1,000$ cells, $SCR = 15,000$ cells/sec, $PCR = 59,000$ cells/sec

Type D: $MBS = 1,000$ cells, $SCR = 15,000$ cells/sec, $PCR = 367,000$ cells/sec

The following contact parameters are given

For peak rate: $GCRA(1,0)$ and

For average rate: $GCRA(3,8)$

Please determine (you must show how you get the answer):

- a) Maximum number of connections
- b) Minimum buffer size
- c) Maximum queueing delay

4. We consider an analytical model for explicit rate flow control as shown in Figure 8. This scenario is used for the equal ICR case. The following conditions are used:

- There are 2 source groups: $S1$ and $S2$. Where $S1$ consists of 3 sources, while group $S2$ consists of 2 sources.
- The round trip time between $S1$ and its destination, and $S2$ and its destination are 0.015 sec and 0.0005 sec respectively.
- All sources start transmitting data at 3 Mbps ($ICR=3$ Mbps) at time 0.
- The switch service rate is 155 Mbps. The switch allocation bandwidth is 95% of its full rate. However, when the queue length reaches a certain threshold, only 80% of its full bandwidth is allocated.
- The following parameters are used: $PCR=155$ Mbps, $RIF=1/256$.
- All sources are saturated sources, e.g. always send data as high as requested by the network.

Hint: The $S2$ rate converts to ER before $S1$ due to a shorter round trip time delay]. All necessary formulas are shown in Figure 9. The switch queue is not fully utilised since the total offered load is less than the service rate.

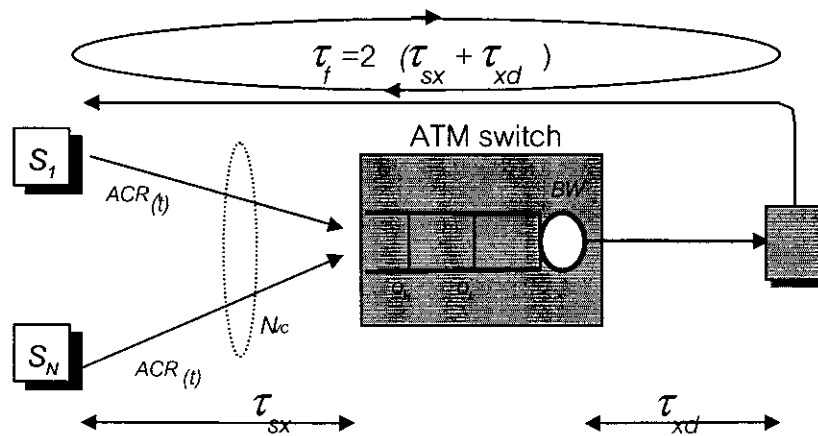

Figure 8 Analytical model for explicit rate flow control

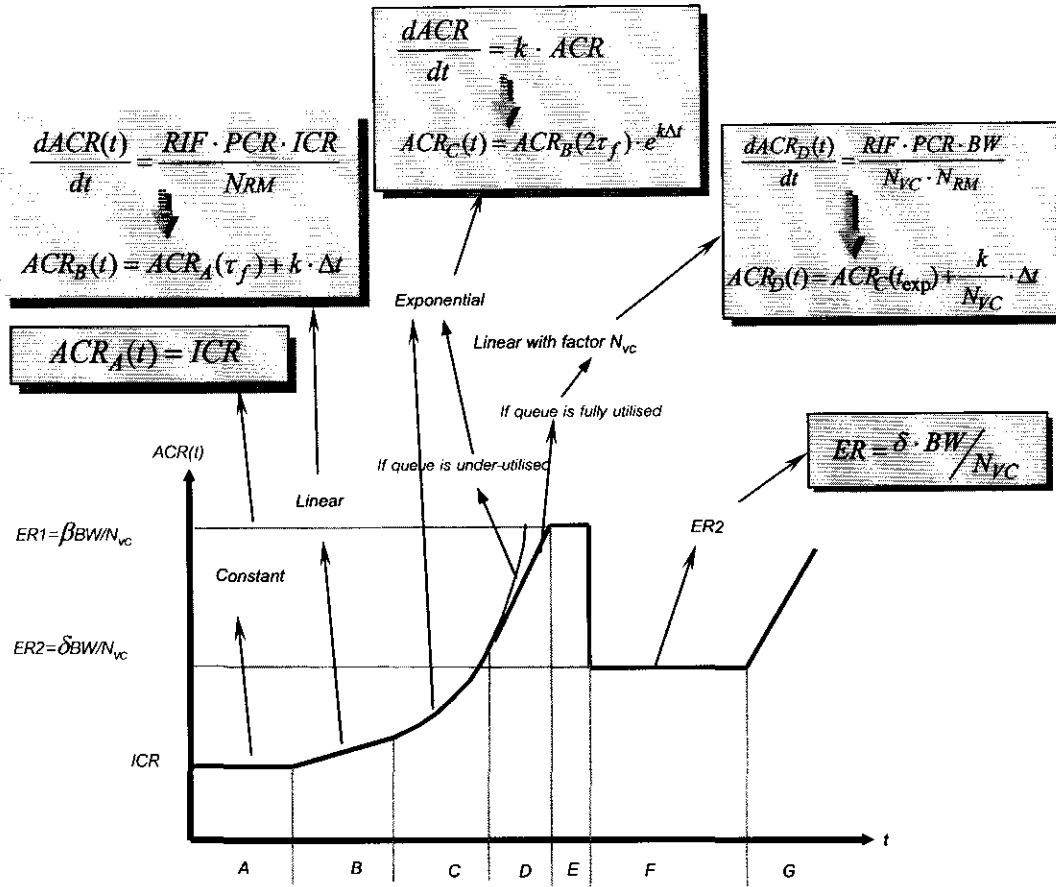

Figure 9 Source rate behaviour as a function of time with equal ICR

- 4.1 Draw a graph of transmission rate of the source S2, (5 Marks)
- 4.2 What are the values of ER1 and ER2? (5 Marks)
- 4.3 What is the condition that phase D will not be happen? (5 Marks)
- 4.4 What are the maximum time period of phase A and B? (5 Marks)