



Prince of Songkla University
Faculty of Engineering

Final Examination
22 February 2008
215-231 Thermodynamics II

Semester 2/2550
Time 9:00 – 12:00
Room: A 300, 302, 305

Name _____ ID _____

Direction:

1. All types of calculator, and dictionary are permitted.
2. There are totally 6 problems

Gumpon Prateepchai kul
Instructor

Problem No.	Full score	Your mark
1	10	
2	15	
3	10	
4	15	
5	25	
6	25	
Total	100	

Name _____ ID _____

- 1) A steam power plant operates on a simple ideal Rankine cycle between the pressure limits of 3 MPa and 50 kPa. The temperature of the steam at the turbine inlet is $400\text{ }^{\circ}\text{C}$, and the mass flow rate of steam through the cycle is 60 kg/s. Show the cycle on a T-s diagram with respect to saturation lines, and determine
- (a) the thermal efficiency of the cycle and
 - (b) the net power output of the power plant

(10 marks)

Name _____ ID _____

2) A simple Brayton or gas turbine cycle using air as the working fluid has a pressure ratio of 8. The minimum and maximum temperatures in the cycle are 310 and 1150 K. Assuming an isentropic efficiency of 75 percent for the compressor and 82 percent for the turbine, determine

- (a) the air temperature at the turbine exit
- (b) the net work output
- (c) the thermal efficiency

(15 marks)

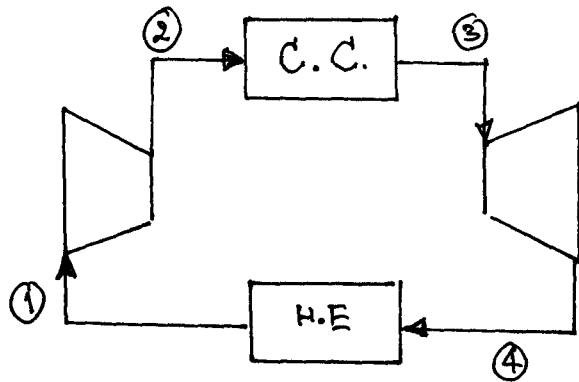

Name _____ ID _____

3) From the relation of the specific heat below

$$C_p - C_v = -T \left(\frac{\partial v}{\partial T} \right)_p^2 \left(\frac{\partial P}{\partial v} \right)_T$$

Derive the expression for ideal gas.

(10 marks)

Name _____ ID _____

4) Using Joule-Thomson coefficient

$$\mu = -\frac{1}{C_p} \left[v - T \left(\frac{\partial v}{\partial T} \right)_p \right]$$

If a gas whose equation of state is

$$P(v-a) = RT$$

Where a is a positive constant. Is it possible to cool this gas by throttling?
(15 marks)

Name _____ ID _____

5) A rigid tank that contains 2 kg of N_2 at 25 °C and 200 kPa is connected to another rigid tank that contains 3 kg of O_2 at 25 °C and 500 kPa. The valve connecting the two tanks is opened, and the two gases are allowed to mix. If the final mixture temperature is 25 °C, determine the volume of each tank and the final mixture pressure. Given $M_{N_2} = 28 \frac{kg}{kmol}$ $M_{O_2} = 32 \frac{kg}{kmol}$ $R_u = 8.314 \frac{kJ}{kmolK}$
(25 marks)

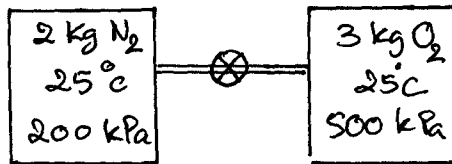

Name _____ ID _____

6) Methane (CH_4) is burned completely with the stoichiometric amount of air during a steady flow combustion process. If both the reactants and the products are maintained at $25^\circ C$ and 1 atm and the water in the products exists in the liquid form, determine the heat transfer from the combustion chamber during this process. What would your answer be if combustion were achieved with 100 percent excess air?
(25 marks)

THERMODYNAMICS

Saturated water—Pressure table

Press., P kPa	Sat. temp., T_{sat} °C	Specific volume, m ³ /kg		Internal energy, kJ/kg			Enthalpy, kJ/kg			Entropy, kJ/kg · K		
		Sat. liquid, v_f	Sat. vapor, v_g	Sat. liquid, u_f	Evap., u_{fg}	Sat. vapor, u_g	Sat. liquid, h_f	Evap., h_{fg}	Sat. vapor, h_g	Sat. liquid, s_f	Evap., s_{fg}	Sat. vapor, s_g
0.6113	0.01	0.001000	206.14	0.00	2375.3	2375.3	0.01	2501.3	2501.4	0.0000	9.1562	9.1562
1.0	6.98	0.001000	129.21	29.30	2355.7	2385.0	29.30	2484.9	2514.2	0.1059	8.8697	8.9756
1.5	13.03	0.001001	87.98	54.71	2338.6	2393.3	54.71	2470.6	2525.3	0.1957	8.6322	8.8279
2.0	17.50	0.001001	67.00	73.48	2326.0	2399.5	73.48	2460.0	2533.5	0.2607	8.4629	8.7237
2.5	21.08	0.001002	54.25	88.48	2315.9	2404.4	88.49	2451.6	2540.0	0.3120	8.3311	8.6432
3.0	24.08	0.001003	45.67	101.04	2307.5	2408.5	101.05	2444.5	2545.5	0.3545	8.2231	8.5776
4.0	28.96	0.001004	34.80	121.45	2293.7	2415.2	121.46	2432.9	2554.4	0.4226	8.0520	8.4746
5.0	32.88	0.001005	28.19	137.81	2282.7	2420.5	137.82	2423.7	2561.5	0.4764	7.9187	8.3951
7.5	40.29	0.001008	19.24	168.78	2261.7	2430.5	168.79	2406.0	2574.8	0.5764	7.6750	8.2515
10	45.81	0.001010	14.67	191.82	2246.1	2437.9	191.83	2392.8	2584.7	0.6493	7.5009	8.1502
15	53.97	0.001014	10.02	225.92	2222.8	2448.7	225.94	2373.1	2599.1	0.7549	7.2536	8.0085
20	60.06	0.001017	7.649	251.38	2205.4	2456.7	251.40	2358.3	2609.7	0.8320	7.0766	7.9085
25	64.97	0.001020	6.204	271.90	2191.2	2463.1	271.93	2346.3	2618.2	0.8931	6.9383	7.8314
30	69.10	0.001022	5.229	289.20	2179.2	2468.4	289.23	2336.1	2625.3	0.9439	6.8247	7.7686
40	75.87	0.001027	3.993	317.53	2159.5	2477.0	317.58	2319.2	2636.8	1.0259	6.6441	7.6700
50	81.33	0.001030	3.240	340.44	2143.4	2483.9	340.49	2305.4	2645.9	1.0910	6.5029	7.5939
75	91.78	0.001037	2.217	384.31	2112.4	2496.7	384.39	2278.6	2663.0	1.2130	6.2434	7.4564
Press., MPa												
0.100	99.63	0.001043	1.6940	417.36	2088.7	2506.1	417.46	2258.0	2675.5	1.3026	6.0568	7.3594
0.125	105.99	0.001048	1.3749	444.19	2069.3	2513.5	444.32	2241.0	2685.4	1.3740	5.9104	7.2844
0.150	111.37	0.001053	1.1593	466.94	2052.7	2519.7	467.11	2226.5	2693.6	1.4336	5.7891	7.2233
0.175	116.06	0.001057	1.0036	486.80	2038.1	2524.9	486.99	2213.6	2700.6	1.4849	5.6863	7.1717
0.200	120.23	0.001061	0.8857	504.49	2025.0	2529.5	504.70	2201.9	2706.7	1.5301	5.5973	7.1271
0.225	124.00	0.001064	0.7933	520.47	2013.1	2533.6	520.72	2191.3	2712.1	1.5706	5.5173	7.0878
0.250	127.44	0.001067	0.7187	535.10	2002.1	2537.2	535.37	2181.5	2716.9	1.6072	5.4453	7.0527
0.275	130.60	0.001070	0.6573	548.59	1991.9	2540.5	548.89	2172.4	2721.3	1.6408	5.3801	7.0209
0.300	133.55	0.001073	0.6058	561.15	1982.4	2543.6	561.47	2163.8	2725.3	1.6718	5.3201	6.9919
0.325	136.30	0.001076	0.5620	572.90	1973.5	2546.4	573.25	2155.8	2729.0	1.7006	5.2645	6.9652
0.350	138.88	0.001079	0.5243	583.95	1965.0	2548.9	584.33	2148.1	2732.4	1.7275	5.2130	6.9405
0.375	141.32	0.001081	0.4914	594.40	1956.9	2551.3	594.81	2140.8	2735.6	1.7528	5.1647	6.9175
0.40	143.63	0.001084	0.4625	604.31	1949.3	2553.6	604.74	2133.8	2738.6	1.7766	5.1193	6.8959
0.45	147.93	0.001088	0.4140	622.77	1934.9	2557.6	623.25	2120.7	2743.9	1.8207	5.0399	6.8565
0.50	151.86	0.001093	0.3749	639.68	1921.6	2561.2	640.23	2108.5	2748.7	1.8607	4.9606	6.8213
0.55	155.48	0.001097	0.3427	655.32	1909.2	2564.5	665.93	2097.0	2753.0	1.8973	4.8900	6.7893
0.60	158.85	0.001101	0.3157	669.90	1897.5	2567.4	670.56	2086.3	2756.8	1.9312	4.8208	6.7600
0.65	162.01	0.001104	0.2927	683.56	1886.5	2570.1	684.28	2076.0	2760.3	1.9627	4.7703	6.7331
0.70	164.97	0.001108	0.2729	696.44	1876.1	2572.5	697.22	2066.3	2763.5	1.9922	4.7198	6.7080
0.75	167.78	0.001112	0.2556	708.64	1866.1	2574.7	709.47	2057.0	2766.4	2.0200	4.6697	6.6847
0.80	170.43	0.001115	0.2404	720.22	1856.6	2576.8	721.11	2048.0	2769.1	2.0462	4.6196	6.6628
0.85	172.96	0.001118	0.2270	731.27	1847.4	2578.7	732.22	2039.4	2771.6	2.0710	4.5711	6.6421
0.90	175.38	0.001121	0.2150	741.83	1838.6	2580.5	742.83	2031.1	2773.9	2.0946	4.5230	6.6226
0.95	177.69	0.001124	0.2042	751.95	1830.2	2582.1	753.02	2023.1	2776.1	2.1172	4.4809	6.6041
1.00	179.91	0.001127	0.19444	761.68	1822.0	2583.6	762.81	2015.3	2778.1	2.1387	4.4478	6.5865
1.10	184.09	0.001133	0.17753	780.09	1806.3	2586.4	781.34	2000.4	2871.7	2.1792	4.3744	6.5536
1.20	187.99	0.001139	0.16333	797.29	1791.5	2588.8	798.65	1986.2	2784.8	2.2166	4.3067	6.5233
1.30	191.64	0.001144	0.15125	813.44	1777.5	2591.0	814.93	1972.7	2787.6	2.2515	4.2438	6.4953

Superheated water (Continued)

T °C	v m ³ /kg	u kJ/kg	h kJ/kg	s kJ/kg · K	v m ³ /kg	u kJ/kg	h kJ/kg	s kJ/kg · K	v m ³ /kg	u kJ/kg	h kJ/kg	s kJ/kg · K
P = 1.00 MPa (179.91°C)				P = 1.20 MPa (187.99°C)				P = 1.40 MPa (185.07°C)				
Sat.	0.19444	2583.6	2778.1	6.5865	0.16333	2588.8	2784.8	6.5233	0.14084	2592.8	2790.0	6.4693
200	0.2060	2621.9	2827.9	6.6940	0.16930	2612.8	2815.9	6.5898	0.14302	2603.1	2833.3	6.4975
250	0.2327	2709.9	2942.6	6.9247	0.19234	2704.2	2935.0	6.8294	0.16350	2698.3	297.2	6.7467
300	0.2579	2793.2	3051.2	7.1229	0.2138	2789.2	3045.8	7.0317	0.18228	2785.2	300.4	6.9534
350	0.2825	2875.2	3157.7	7.3011	0.2345	2872.2	3153.6	7.2121	0.2003	2869.2	319.5	7.1360
400	0.3066	2957.3	3263.9	7.4651	0.2548	2954.9	3260.7	7.3774	0.2178	2952.5	327.5	7.3026
500	0.3541	3124.4	3478.5	7.7622	0.2946	3122.8	3476.3	7.6759	0.2521	3121.1	347.4	7.6027
600	0.4011	3296.8	3697.9	8.0290	0.3339	3295.6	3696.3	7.9435	0.2860	3294.4	369.8	7.8710
700	0.4478	3475.3	3923.1	8.2731	0.3729	3474.4	3922.0	8.1881	0.3195	3473.6	397.8	8.1160
800	0.4943	3660.4	4154.7	8.4996	0.4118	3659.7	4153.8	8.4148	0.3528	3659.0	413.0	8.3431
900	0.5407	3852.2	4392.9	8.7118	0.4505	3851.6	4392.2	8.6272	0.3861	3851.1	431.5	8.5556
1000	0.5871	4050.5	4637.6	8.9119	0.4892	4050.0	4637.0	8.8274	0.4192	4049.5	461.6	8.7559
1100	0.6335	4255.1	4888.6	9.1017	0.5278	4254.6	4888.0	9.0172	0.4524	4254.1	481.5	8.9457
1200	0.6798	4465.6	5145.4	9.2822	0.5665	4465.1	5144.9	9.1977	0.4855	4464.7	511.4	9.1262
1300	0.7261	4681.3	5407.4	9.4543	0.6051	4680.9	5407.0	9.3698	0.5186	4680.4	541.6	9.2984
P = 1.60 MPa (201.41°C)				P = 1.80 MPa (207.15°C)				P = 2.00 MPa (212.42°C)				
Sat.	0.12380	2596.0	2794.0	6.4218	0.11042	2598.4	2797.1	6.3794	0.09963	2600.3	279.5	6.3409
225	0.13287	2644.7	2857.3	6.5518	0.11673	2636.6	2846.7	6.4808	0.10377	2628.3	281.5	6.4147
250	0.14184	2692.3	2919.2	6.6732	0.12497	2686.0	2911.0	6.6066	0.11144	2679.6	291.5	6.5453
300	0.15862	2781.1	3034.8	6.8844	0.14021	2776.9	3029.2	6.8226	0.12547	2772.6	301.5	6.7664
350	0.17456	2866.1	3145.4	7.0694	0.15457	2863.0	3141.2	7.0100	0.13857	2859.8	311.7	6.9563
400	0.19005	2950.1	3254.2	7.2374	0.16847	2947.7	3250.9	7.1794	0.15120	2945.2	321.6	7.1271
500	0.2203	3119.5	3472.0	7.5390	0.19550	3117.9	3469.8	7.4825	0.17568	3116.2	341.6	7.4317
600	0.2500	3293.3	3693.2	7.8080	0.2220	3292.1	3691.7	7.7523	0.19960	3290.9	361.1	7.7024
700	0.2794	3472.7	3919.7	8.0535	0.2482	3471.8	3918.5	7.9983	0.2232	3470.9	391.4	7.9487
800	0.3086	3658.3	4152.1	8.2808	0.2742	3657.6	4151.2	8.2258	0.2467	3657.0	411.3	8.1765
900	0.3377	3850.5	4390.8	8.4935	0.3001	3849.9	4390.1	8.4386	0.2700	3849.3	431.4	8.3895
1000	0.3668	4049.0	4635.8	8.6938	0.3260	4048.5	4635.2	8.6391	0.2933	4048.0	461.6	8.5901
1100	0.3958	4253.7	4887.0	8.8837	0.3518	4253.2	4886.4	8.8290	0.3166	4252.7	481.5	8.7800
1200	0.4248	4464.2	5143.9	9.0643	0.3776	4463.7	5143.4	9.0096	0.3398	4463.3	511.2	8.9607
1300	0.4538	4679.9	5406.0	9.2364	0.4034	4679.5	5405.6	9.1818	0.3631	4679.0	541.1	9.1329
P = 2.50 MPa (223.99°C)				P = 3.00 MPa (233.90°C)				P = 3.50 MPa (242.60°C)				
Sat.	0.07998	2603.1	2803.1	6.2575	0.06668	2604.1	2804.2	6.1869	0.05707	2603.7	281.3	6.1253
225	0.08027	2605.6	2806.3	6.2639								
250	0.08700	2662.6	2880.1	6.4085	0.07058	2644.0	2855.8	6.2872	0.05872	2623.7	281.9	6.1749
300	0.09890	2761.6	3008.8	6.6438	0.08114	2750.1	2993.5	6.5390	0.06842	2738.0	291.5	6.4461
350	0.10976	2851.9	3126.3	6.8403	0.09053	2843.7	3115.3	6.7428	0.07678	2835.3	301.0	6.6579
400	0.12010	2939.1	3239.3	7.0148	0.09936	2932.8	3230.9	6.9212	0.08453	2926.4	321.3	6.8405
450	0.13014	3025.5	3350.8	7.1746	0.10787	3020.4	3344.0	7.0834	0.09196	3015.3	331.2	7.0052
500	0.13993	3112.1	3462.1	7.3234	0.11619	3108.0	3456.5	7.2338	0.09918	3103.0	341.0	7.1572
600	0.15930	3288.0	3686.3	7.5960	0.13243	3285.0	3682.3	7.5085	0.11324	3282.1	361.8	7.4339
700	0.17832	3468.7	3914.5	7.8435	0.14838	3466.5	3911.7	7.7571	0.12699	3464.3	391.8	7.6837
800	0.19716	3655.3	4148.2	8.0720	0.16414	3653.5	4145.9	7.9862	0.14056	3651.8	411.3	7.9134
900	0.21590	3847.9	4387.6	8.2853	0.17980	3846.5	4385.9	8.1999	0.15402	3845.0	431.1	8.1276
1000	0.2346	4046.7	4633.1	8.4861	0.19541	4045.4	4631.6	8.4009	0.16743	4044.1	461.1	8.3288
1100	0.2532	4251.5	4884.6	8.6762	0.21098	4250.3	4883.3	8.5912	0.18080	4249.2	481.9	8.5192
1200	0.2718	4462.1	5141.7	8.8569	0.22652	4460.9	5140.5	8.7720	0.19415	4459.8	511.3	8.7000
1300	0.2905	4677.8	5404.0	9.0291	0.24206	4676.6	5402.8	8.9442	0.20749	4675.5	541.7	8.8723

Ideal-gas properties of air

T K	h kJ/kg	P_r	u kJ/kg	v_r	s° kJ/kg · K	T K	h kJ/kg	P_r	u kJ/kg	v_r	s° kJ/kg · K
200	199.97	0.3363	142.56	1707.0	1.29559	580	586.04	14.38	419.55	115.7	2.37348
210	209.97	0.3987	149.69	1512.0	1.34444	590	596.52	15.31	427.15	110.6	2.39140
220	219.97	0.4690	156.82	1346.0	1.39105	600	607.02	16.28	434.78	105.8	2.40902
230	230.02	0.5477	164.00	1205.0	1.43557	610	617.53	17.30	442.42	101.2	2.42644
240	240.02	0.6355	171.13	1084.0	1.47824	620	628.07	18.36	450.09	96.92	2.44356
250	250.05	0.7329	178.28	979.0	1.51917	630	638.63	19.84	457.78	92.34	2.46048
260	260.09	0.8405	185.45	887.8	1.55848	640	649.22	20.64	465.50	88.39	2.47716
270	270.11	0.9590	192.60	808.0	1.59634	650	659.84	21.86	473.25	85.34	2.49364
280	280.13	1.0889	199.75	738.0	1.63279	660	670.47	23.13	481.01	81.39	2.50985
285	285.14	1.1584	203.33	706.1	1.65055	670	681.14	24.46	488.81	78.51	2.52589
290	290.16	1.2311	206.91	676.1	1.66802	680	691.82	25.85	496.62	75.50	2.54175
295	295.17	1.3068	210.49	647.9	1.68515	690	702.52	27.29	504.45	72.56	2.55731
300	300.19	1.3860	214.07	621.2	1.70203	700	713.27	28.80	512.33	69.76	2.57277
305	305.22	1.4686	217.67	596.0	1.71865	710	724.04	30.38	520.23	67.07	2.58810
310	310.24	1.5546	221.25	572.3	1.73498	720	734.82	32.02	528.14	64.53	2.60319
315	315.27	1.6442	224.85	549.8	1.75106	730	745.62	33.72	536.07	62.13	2.61803
320	320.29	1.7375	228.42	528.6	1.76690	740	756.44	35.50	544.02	59.82	2.63280
325	325.31	1.8345	232.02	508.4	1.78249	750	767.29	37.35	551.99	57.63	2.64737
330	330.34	1.9352	235.61	489.4	1.79783	760	778.18	39.27	560.01	55.54	2.66176
340	340.42	2.149	242.82	454.1	1.82790	780	800.03	43.35	576.12	51.64	2.69013
350	350.49	2.379	250.02	422.2	1.85708	800	821.95	47.75	592.30	48.08	2.71787
360	360.58	2.626	257.24	393.4	1.88543	820	843.98	52.59	608.59	44.84	2.74504
370	370.67	2.892	264.46	367.2	1.91313	840	866.08	57.60	624.95	41.85	2.77170
380	380.77	3.176	271.69	343.4	1.94001	860	888.27	63.09	641.40	39.12	2.79783
390	390.88	3.481	278.93	321.5	1.96633	880	910.56	68.98	657.95	36.61	2.82344
400	400.98	3.806	286.16	301.6	1.99194	900	932.93	75.29	674.58	34.31	2.84856
410	411.12	4.153	293.43	283.3	2.01699	920	955.38	82.05	691.28	32.18	2.87324
420	421.26	4.522	300.69	266.6	2.04142	940	977.92	89.28	708.08	30.22	2.89748
430	431.43	4.915	307.99	251.1	2.06533	960	1000.55	97.00	725.02	28.40	2.92128
440	441.61	5.332	315.30	236.8	2.08870	980	1023.25	105.2	741.98	26.73	2.94468
450	451.80	5.775	322.62	223.6	2.11161	1000	1046.04	114.0	758.94	25.17	2.96770
460	462.02	6.245	329.97	211.4	2.13407	1020	1068.89	123.4	776.10	23.72	2.99034
470	472.24	6.742	337.32	200.1	2.15604	1040	1091.85	133.3	793.36	22.29	3.01260
480	482.49	7.268	344.70	189.5	2.17760	1060	1114.86	143.9	810.62	20.14	3.03449
490	492.74	7.824	352.08	179.7	2.19876	1080	1137.89	155.2	827.88	19.98	3.05608
500	503.02	8.411	359.49	170.6	2.21952	1100	1161.07	167.1	845.33	18.896	3.07732
510	513.32	9.031	366.92	162.1	2.23993	1120	1184.28	179.7	862.79	17.886	3.09825
520	523.63	9.684	374.36	154.1	2.25997	1140	1207.57	193.1	880.35	16.946	3.11883
530	533.98	10.37	381.84	146.7	2.27967	1160	1230.92	207.2	897.91	16.064	3.13916
540	544.35	11.10	389.34	139.7	2.29906	1180	1254.34	222.2	915.57	15.241	3.15916
550	555.74	11.86	396.86	133.1	2.31809	1200	1277.79	238.0	933.33	14.470	3.17888
560	565.17	12.66	404.42	127.0	2.33685	1220	1301.31	254.7	951.09	13.747	3.19834
570	575.59	13.50	411.97	121.2	2.35531	1240	1324.93	272.3	968.95	13.069	3.21751

Air

Enthalpy of formation, Gibbs function of formation, and absolute entropy at 25°C, 1 atm

Substance	Formula	\bar{h}_f° kJ/kmol	\bar{g}_f° kJ/kmol	S° kJ/kmol · K
Carbon	C(s)	0	0	5.74
Hydrogen	H ₂ (g)	0	0	130.68
Nitrogen	N ₂ (g)	0	0	191.61
Oxygen	O ₂ (g)	0	0	205.04
Carbon monoxide	CO(g)	-110,530	-137,150	197.65
Carbon dioxide	CO ₂ (g)	-393,520	-394,360	213.80
Water vapor	H ₂ O(g)	-241,820	-228,590	188.83
Water	H ₂ O(l)	-285,830	-237,180	69.92
Hydrogen peroxide	H ₂ O ₂ (g)	-136,310	-105,600	232.63
Ammonia	NH ₃ (g)	-46,190	-16,590	192.33
Methane	CH ₄ (g)	-74,850	-50,790	186.16
Acetylene	C ₂ H ₂ (g)	+226,730	+209,170	200.85
Ethylene	C ₂ H ₄ (g)	+52,280	+68,120	219.83
Ethane	C ₂ H ₆ (g)	-84,680	-32,890	229.49
Propylene	C ₃ H ₆ (g)	+20,410	+62,720	266.94
Propane	C ₃ H ₈ (g)	-103,850	-23,490	269.91
n-Butane	C ₄ H ₁₀ (g)	-126,150	-15,710	310.12
n-Octane	C ₈ H ₁₈ (g)	-208,450	+16,530	466.73
n-Octane	C ₈ H ₁₈ (l)	-249,950	+16,510	350.70