

PRINCE OF SONGKLA UNIVERSITY
FACULTY OF ENGINEERING

Final Examination: Semester 2

Academic Year: 2008

Date: 27 February 2009

Time 9.00-12.00 (3 hours)

Subject Number: 240-631

Room: R 200

Subject Title: Parallel and Distributed Simulation Systems

Exam Duration: 3 hours

This paper has 14 pages, 10 questions and 110 marks (40%).

Authorised Materials:

- Writing instruments (e.g. pens, pencils).
- Textbooks, a notebook, handouts, and dictionaries are permitted.

Instructions to Students:

- Scan all the questions before answering so that you can manage your time better.
- Attempt all questions in **Thai**.
- Write your name and ID on every page.
- Any unreadable parts will be considered wrong.

When drawing diagrams or coding, use good layout, and short comments; marks will not be deducted for minor syntax errors.

NO	Time (Min)	Marks	Collected	NO	Time (Min)	Marks	Collected
1	45	30		7	10	10	
2	10	10		8	15	10	
3	15	10		9	15	10	
4	10	10		10	10	10	
5	10	10		Total	180	120	
6	10	10				40	

ทูลริตในการสอบ

โทษจันต่า ปรึบตกในรายวิชานันแลหพัทการเรียน 1 ภาคการศึกษา

โทษสูงสุด ให้ออก

Question 1

(30 marks; 45 minutes)

- a) What are *time parallel* applications for and what are the cost of such applications? (2 marks)

- b) What are the differences between *Global Virtual Time (GVT)* and *lower bound on the time stamp (LBTS)*? (4 marks)

GVT	LBTS

- c) What are the differences between *Batch fossil collection* and *On-the-fly fossil collection*? (4 marks)

Batch fossil collection	On-the-fly fossil collection

d) What are the pros and cons of *conservative* and *optimistic* algorithms in distributed simulation systems. (6 marks)

Conservative algorithms	Optimistic algorithms

- e) Explain *Storage optimal protocols* and *Artificial Rollback*. When do we need them and how to select which memory can be reclaimed?

(4 marks)

Storage optimal protocols	Artificial Rollback

f) What are the benefits of a distance matrix? (2 marks)

g) What are anti-messages for? (4 marks)

h) How does message sendback work? And what is it for? (4 marks)

Question 2

(10 marks; 10 minutes)

What are the motivations and benefits of the following algorithms?

a) Event Retraction

b) Lazy Cancellation

c) Lazy Re-Evaluation

Question 3 (10 marks; 15 minutes)

What are the pros and cons of the following algorithms?

a) Copy State Saving

b) Infrequent State Saving

c) Incremental State Saving

d) Reverse Computation

Question 4

(10 marks; 10 minutes)

a) Explain the following problems.

(6 marks)

- Zero Lookahead

- Simultaneous Events

b) Give a solution to solve the above problems.

(4 marks)

Question 5 (10 marks; 10 minutes)

a) What are transient messages? (2 marks)

b) What impacts can they cause? (2 marks)

c) Explain the Samadi Algorithm that solves the transient message problem and simultaneous reporting problem with a diagram. (6 marks)

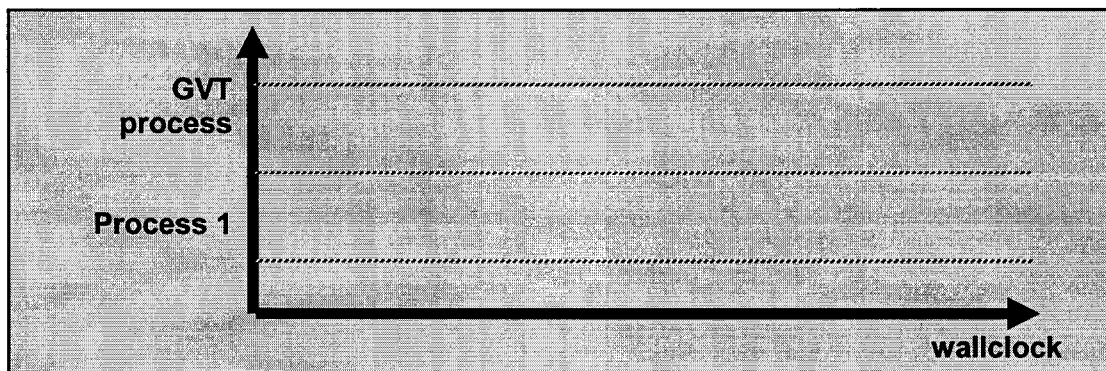

Question 6

(10 marks; 10 minutes)

- a) What are the benefits of getting a Global Virtual Time (GVT) without sending a request and collecting reports from logical processes. (2 marks)

- b) Tell what need to be collected in a token sent round the logical processes and the reasons why. (4 marks)

- c) From the below picture, **circle** cut messages. (2 marks)

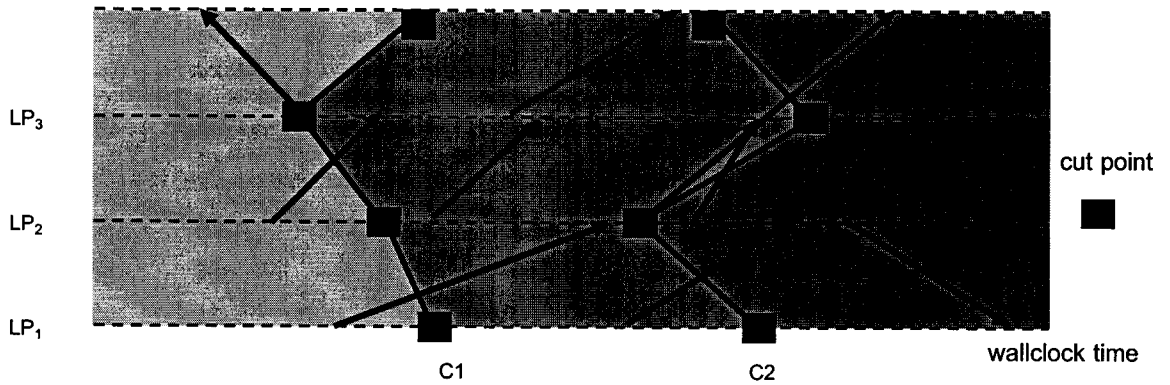

Question 7

(6 marks; 10 minutes)

In case of Storage Optimal Protocols, **color or mark** the events in the following picture and tell which are eligible or ineligible for deletion and which events can storage be reclaimed.

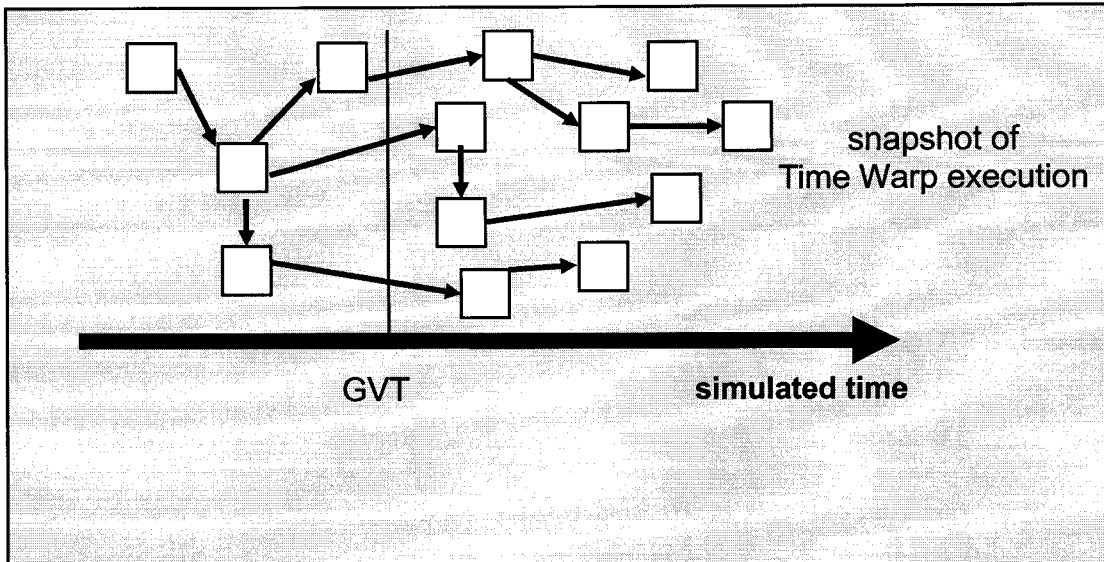

Question 8

(10 marks; 15 minutes)

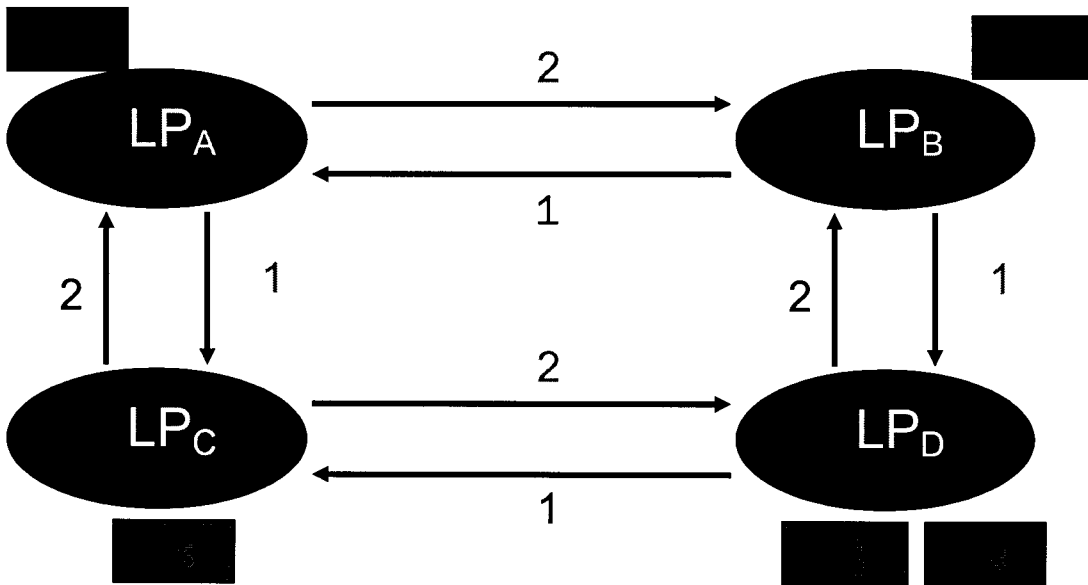

a) From the above topology, fill in the following distance matrix.

(2 marks)

	A	B	C	D
A				
B				
C				
D				

b) Calculate the Lower Bound on the Timestamp (LBTS) on each logical process.

(4 marks)

A	
B	
C	
D	

c) Which messages depend on which?

(2 marks)

Question 9

(10 marks; 15 minutes)

Given a below sequence of references to blocks in memory, determine number of hits and misses using Least Recently Used (LRU) stack replacement. Suppose that there are 4 processors and each stack can contain 4 addresses. Trace Drive Cache Simulation using Time Parallel Simulation: Relaxation Approach.

4 3 2 7 1 3 8 1 2 8 3 4 5 6 7 5 1 5 6 3 4 3 6 4

Name _____ ID _____

a) first iteration: assume stack is initially empty (5 marks)

4 3 2 7 1 3 8 1 2 8 3 4 5 6 7 5 1 5 6 3 4 3 6 4

b) second iteration: processor i uses final state of processor i-1 as initial state

(5 marks)

4 3 2 7 1 3 8 1 2 8 3 4 5 6 7 5 1 5 6 3 4 3 6 4

Question 10

(10 marks; 10 minutes)

From the message counters in the following topologies of logical processes, use the Flush Barrier to demonstrate if there are transient messages and how many?

a) Tree

(5 marks)

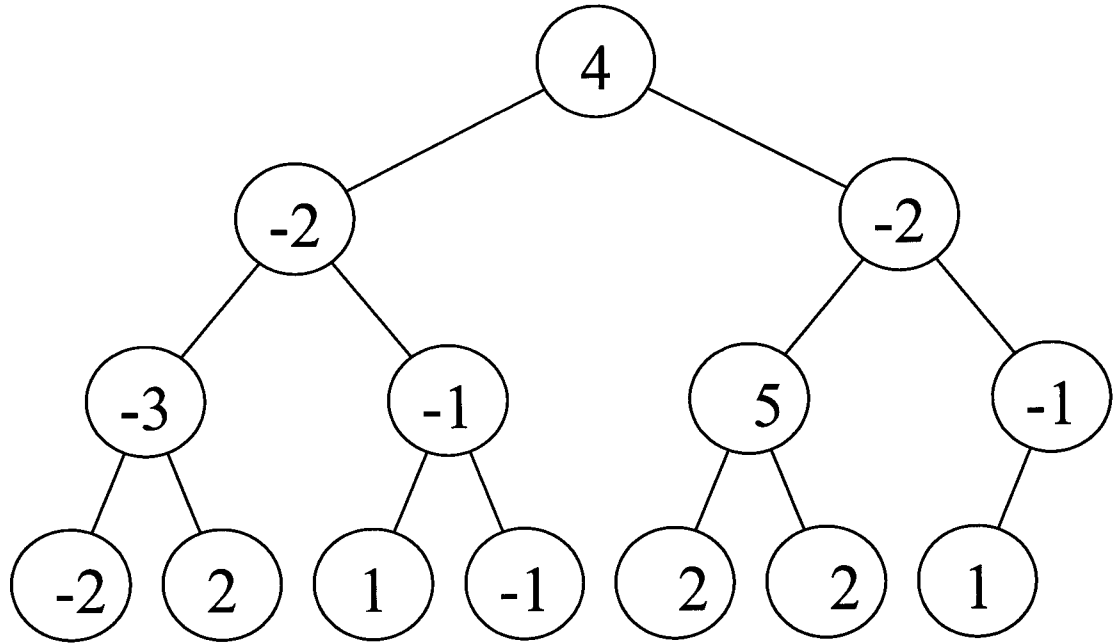

There are _____ transient messages.

b) Butterfly

(5 marks)



There are _____ transient messages.

----End of Examination----

Pichaya Tandayya, Lecturer