

มหาวิทยาลัยสงขลานครินทร์  
คณะวิศวกรรมศาสตร์



Prince of Songkla University  
Faculty of Engineering

สอบประจำภาคการศึกษาที่ 1

ปีการศึกษา 2554

วันที่ 3 สิงหาคม 2554

เวลา 9.00 - 12.00 น

วิชา Prestressed Concrete ตอน 01 (๑๑1-414)

ห้องสอบ R 200

ชื่อ-สกุล.....รหัส.....

**คำชี้แจง: โปรดอ่านคำชี้แจงก่อนลงมือทำข้อสอบ**

1. ข้อสอบทั้งหมดมี 6 ข้อใหญ่ คะแนนรวม 60 คะแนน ดังแสดงในตารางข้างล่าง
2. ข้อสอบมีทั้งหมด 11 หน้า (รวมปก) ผู้สอบต้องตรวจสอบว่ามีครบทุกหน้าหรือไม่ (ก่อนลงมือทำ)
3. ห้ามฉีกหรือแกะข้อสอบออกจากเล่ม
4. ให้ทำหมดทุกข้อลงในกระดาษคำตอบนี้ หากไม่พอให้ใช้หน้าว่างที่ให้มาในแต่ละข้อ
5. ไม่อนุญาตให้นำเอกสารใดๆ เข้าห้องสอบได้
6. อนุญาตให้ใช้เครื่องคิดเลขได้ทุกชนิด
7. ห้ามหยิบ หรือยืมสิ่งของใดๆ ของผู้อื่นในห้องสอบ
8. อนุญาตให้ตอบด้วยดินสอดำได้ (ควรใช้ชนิด B)

**ตารางคะแนน**

ข้อที่	คะแนนเต็ม	ได้
1	10	
2	10	
3	10	
4	10	
5	12	
6	8	
รวม	60	

**(10 Point) Problem 1:** Determine maximum live load capacity of prestressed concrete beam under conditions as follows:

- A prestressed concrete rectangular beam 50 cm by 80 cm has a simple span of 8 m.
- The prestressing tendon is located as shown in figure and produces an effective prestress of 160,000 kg.
- For the top extreme fiber @ mid span: concrete stress < 70 ksc (compression)
- For the bottom extreme fiber: concrete stress @ mid span < 17.45 ksc (compression)

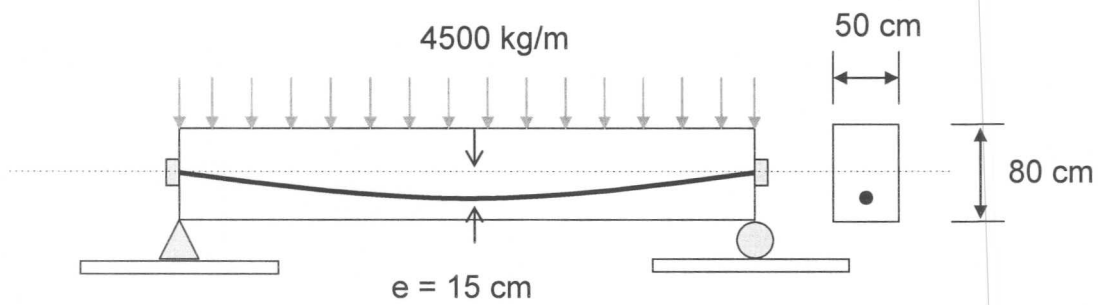

(10 Point) **Problem 2:** A prestensioned prestressed slab (hollow section as shown in Figure) has a simple span of 5 m. Determine: (Assume that prior to transfer, the jacking force on the tendon was  $0.75f_{ps}$ )

2.1) the concrete fiber stresses (at transfer) at the centroid of the tendon for the mid-span section of the beam

2.2) the magnitude of loss in prestress due to the effect of elastic shortening of the concrete.

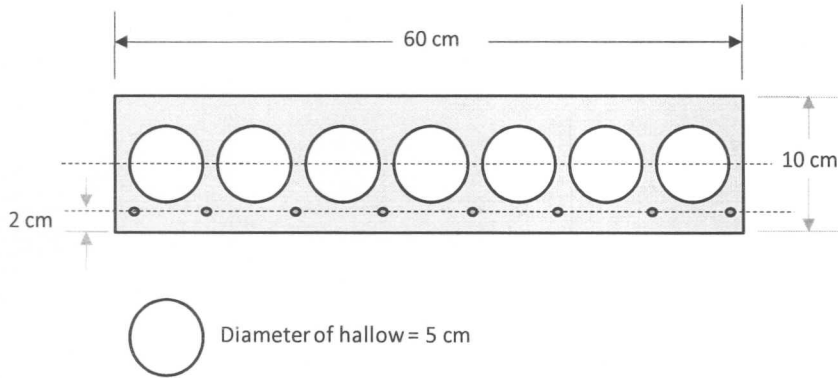

$$f'_{ci} = 250 \text{ ksc}$$

Compressive strength of concrete:

$$E_c = 15200\sqrt{f'_c} \text{ ksc}$$

Prestressing tendon:

$$f_{ps} = 13,500 \text{ ksc}$$

$$E_{ps} = 1,900,000 \text{ ksc}$$

$$A_{ps} = 8 - \text{PC5A} = 1.57 \text{ cm}^2$$

Elastic shortening loss:

$$\Delta f_{pES} = \frac{E_s f_c}{E_c} = \frac{E_s P_i}{E_c A_c} = n \frac{P_i}{A_c} = n f_{cs}$$

**(10 Point) Problem 3:** A prestensioned prestressed slab (from problem 2) has a simple span of 5 m.

Determine: Relaxation loss using EIT (Relative Humidity = 75% and other sustained dead load =  $150 \text{ kg/m}^2$ )

**EIT Standard:**

$$RE = 1270 - 0.4ES - 0.2(SH + CR)$$

$$SH = 1200 - 11RH$$

$$CR = 12f_{cir} - 7f_{cds}$$

---

**(10 Point) Problem 4:**

A prestressed concrete beam is continuous over two spans and its curved tendon is to be tensioned from the both end. Compute the loss of prestress due to friction, from one end to the center of the beam (A to E). The coefficient of friction between the cable and the duct is taken as 0.45 and the average “wobble” or length effect is represented by  $K = 0.0021$  per meter. (Using the conventional method by separating to several ranges)

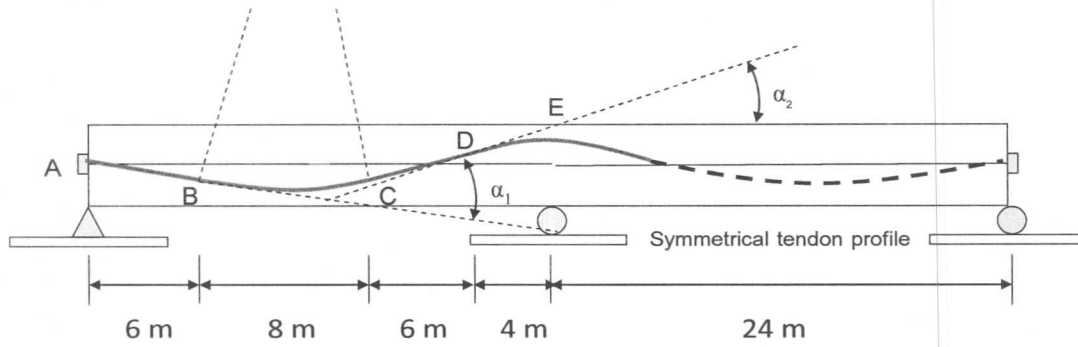

**Eccentricity of tendon:**

Position	Above center line (m)	Below center line (m)
A	0	0
B	-	0.26
mid-point between B and C	0	0.40
C	-	0.26
D	0.35	-
E	0.50	-

**Friction loss:**

$$\Delta f_{pF} = f_1 - f_2 = f_1(1 - e^{-\mu\alpha - KL})$$

**(12 Point) Problem 5:** The simply supported beam as shown below is to carry a uniform distributed service dead and live load totaling 1000 kg/m over the 12 m span, in addition to its own weight. Normal concrete having density of  $2400 \text{ kg/m}^3$  will be used. The beam will be pretensioned using multiple seven-wire strands; eccentricity is constant and equal to 150 mm. The prestress force  $P_i$  immediately after transfer (after elastic shortening loss) is 80 Ton. Time-dependent losses due to shrinkage, creep, and relaxation total 15 percent of the initial prestress force.

Find the concrete flexural stresses at mid-span section and draw stress diagram on the cross section under:

- 5.1) initial condition
- 5.2) initial condition plus Dead load
- 5.3) after transfer
- 5.4) Full service load

Moment of inertia ( $I$ ) =  $5 \times 10^5 \text{ cm}^4$  Concrete area ( $A$ ) =  $1500 \text{ cm}^2$  Section modulus (both  $S_1$  and  $S_2$ ) =  $16,000 \text{ cm}^3$

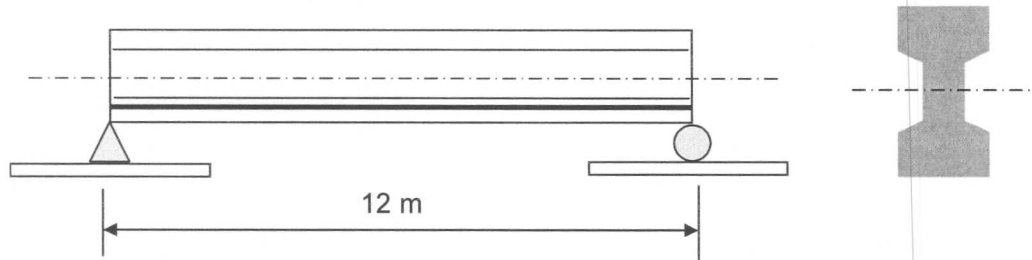

**(8 Point) Problem 6:** From problem 5.1: Determine the stress change in the prestressing steel tendon at mid-span resulting from application as follows ( $E_s/E_c = 8$ ): At superimposed and live load

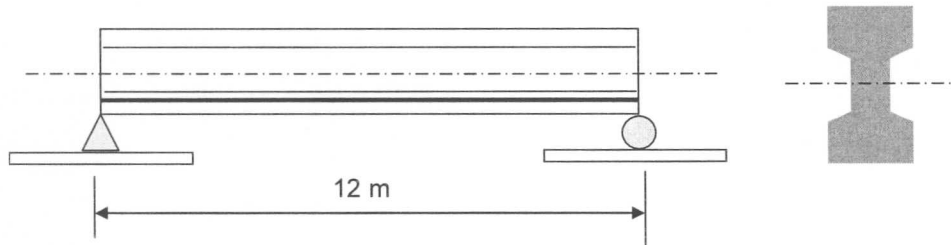

The stress change in the steel tendon

$$\Delta f_{ps} = \frac{E_s}{E_c} (\Delta f_{cps})$$

---