

คณะวิศวกรรมศาสตร์  
มหาวิทยาลัยสงขลานครินทร์

การสอบปลายภาค ประจำปีการศึกษาที่ 2

ประจำปีการศึกษา 2558

วันที่ 4 พฤษภาคม 2559

เวลา 13.30-16.30 น.

วิชา 215-332 Engineering Thermodynamics II

ห้อง S 102

**คำสั่ง**

1. ข้อสอบมีทั้งหมด 5 ข้อ ทำทุกข้อกระดาษคำตอบ
2. ห้ามนำโทรศัพท์เข้า
3. ห้าม load เอกสารใดๆ ลงในเครื่องคิดเลข หากพบ ถือว่าเจตนาทุจริต
4. นำพจนานุกรมเข้าห้องสอบได้

รศ.กำพล ประทีปชัยกูร

ผู้ออกข้อสอบ

รหัส..... ชื่อ-สกุล..... ตอน.....

รหัส..... ชื่อ-สกุล..... ตอน.....

1) A  $1 \text{ m}^3$  rigid tank is divided into two equal compartments by a partition. One compartment contains  $\text{O}_2$  at  $30^\circ\text{C}$  and 150 kPa, and the other compartment contains  $\text{N}_2$  at  $40^\circ\text{C}$  and 250 kPa. Suddenly the partition is removed, and the two gases are allowed to mix. Heat is lost to the surrounding air during this process in the amount of 25 kJ. Determine a) the final mixture temperature b) the final mixture pressure

Given:

$$M_{\text{O}_2} = 32 \frac{\text{kg}}{\text{kmol}}, \quad M_{\text{N}_2} = 28 \frac{\text{kg}}{\text{kmol}},$$

$$C_{v,\text{O}_2} = 0.658 \frac{\text{kJ}}{\text{kg}\cdot\text{K}}, \quad C_{v,\text{N}_2} = 0.743 \frac{\text{kJ}}{\text{kg}\cdot\text{K}}, \quad R_u = 8.314 \frac{\text{kPa}\cdot\text{m}^3}{\text{kmol}\cdot\text{K}}$$

(25 marks)

รหัส..... ชื่อ-สกุล..... ตอน.....

2) Liquid propane  $C_3H_8$  enters a combustion chamber at  $25^\circ\text{C}$  at a rate of  $1.2 \frac{\text{kg}}{\text{min}}$  where it is mixed and burned with 150 % excess air that enters the combustion chamber at  $12^\circ\text{C}$ . If the combustion is complete and the exit temperature of the combustion gases is 1200 K, determine  
 a) the mass flow rate of air    b) the rate of heat transfer from the combustion chamber. Given:

$$M_{air} = 29 \frac{\text{kg}}{\text{kmol}}, \quad \bar{h}_f^\circ \text{ of liquid propane} = -118910 \text{ kJ/kmol},$$

$$Q_{in} + W_{in} + \sum N_i(\bar{h}_i^\circ + \bar{h} - \bar{h}^\circ)_i = Q_{out} + W_{out} + \sum N_e(\bar{h}_e^\circ + \bar{h} - \bar{h}^\circ)_e \quad (15-9)$$

Energy transfer in per mole of fuel  
by heat, work, and mass

Energy transfer out per mole of fuel  
by heat, work, and mass

(25 marks)

รหัส.....ชื่อ-สกุล..... ตอน.....

รหัส..... ชื่อ-สกุล..... ตอน.....

3) The closed feedwater heater of a regenerative Rankine cycle is to heat 6000 kPa feedwater from  $250^{\circ}\text{C}$  to a saturated liquid. The turbine supplies bleed steam at 5000 kPa and  $350^{\circ}\text{C}$  to this unit. This steam is condensed to a saturated liquid before entering the pump. Calculate the amount of bleed steam required to heat 1 kg of feedwater in this unit. (25 marks)

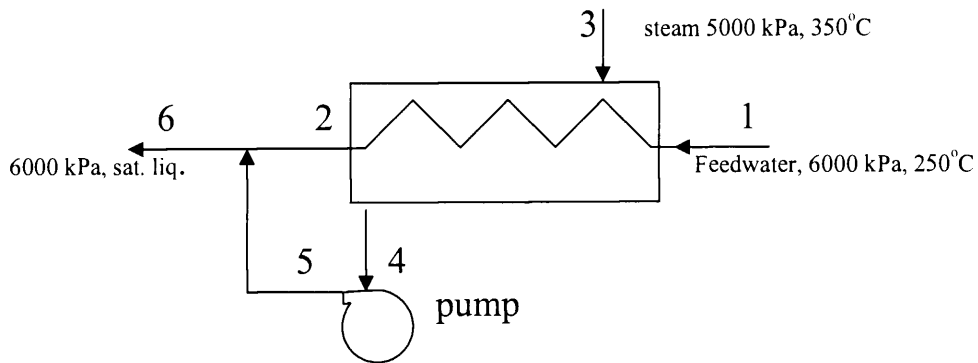

รหัส.....ชื่อ-สกุล..... ตอน.....

รหัส..... ชื่อ-สกุล..... ตอน.....

4) In a 30 cm. diameter cooling section, air at 1 atm, 35°C and 60% RH enter this section at 120 m/min. The air is cooled by passing it over a cooling coil through which cold water flows. The water experiences a temperature rise of 8°C. The air leaves the cooling section saturated at 20°C. Determine a) the rate of heat transfer b) the mass flow rate of the water c) the exit velocity of the air stream.

Given:  $C_{p,water} = 4.18 \frac{kJ}{kg.C}$  (25 marks)

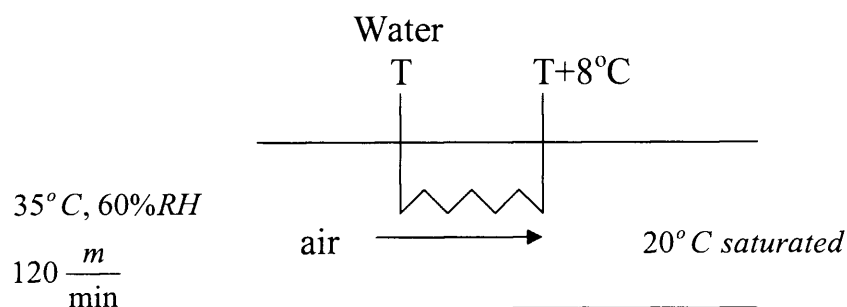

รหัส.....ชื่อ-สกุล..... ตอน.....



รหัส..... ชื่อ-สกุล..... ตอน.....

5) A certain natural gas has the following volumetric analysis: 65% CH<sub>4</sub>, 8% H<sub>2</sub>, 18% N<sub>2</sub>, 3% O<sub>2</sub>, and 6% CO<sub>2</sub>. This gas is now burned completely with stoichiometric amount of moist air that enters the combustion chamber at 25°C, 1 atm and 85% relative humidity. What is the A/F ratio for this combustion process?

(25 marks)

รหัส.....ชื่อ-สกุล..... ตอน.....

TABLE A-4

Saturated water—Temperature table

Temp., $T$ °C	Sat. press., $P_{\text{sat}}$ kPa	Specific volume, $\text{m}^3/\text{kg}$		Internal energy, kJ/kg			Enthalpy, kJ/kg			Entropy, kJ/kg·K		
		Sat. liquid, $v_f$	Sat. vapor, $v_g$	Sat. liquid, $u_f$	Evap., $u_{fg}$	Sat. vapor, $u_g$	Sat. liquid, $h_f$	Evap., $h_{fg}$	Sat. vapor, $h_g$	Sat. liquid, $s_f$	Evap., $s_{fg}$	Sat. vapor, $s_g$
0.01	0.6117	0.001000	206.00	0.000	2374.9	2374.9	0.001	2500.9	2500.9	0.0000	9.1556	9.1556
5	0.8725	0.001000	147.03	21.019	2360.8	2381.8	21.020	2489.1	2510.1	0.0763	8.9487	9.0249
10	1.2281	0.001000	106.32	42.020	2346.6	2388.7	42.022	2477.2	2519.2	0.1511	8.7488	8.8999
15	1.7057	0.001001	77.885	62.980	2332.5	2395.5	62.982	2465.4	2528.3	0.2245	8.5559	8.7803
20	2.3392	0.001002	57.762	83.913	2318.4	2402.3	83.915	2453.5	2537.4	0.2965	8.3696	8.6661
25	3.1698	0.001003	43.340	104.83	2304.3	2409.1	104.83	2441.7	2546.5	0.3672	8.1895	8.5567
30	4.2469	0.001004	32.879	125.73	2290.2	2415.9	125.74	2429.8	2555.6	0.4368	8.0152	8.4520
35	5.6291	0.001006	25.205	146.63	2276.0	2422.7	146.64	2417.9	2564.6	0.5051	7.8466	8.3517
40	7.3851	0.001008	19.515	167.53	2261.9	2429.4	167.53	2406.0	2573.5	0.5724	7.6832	8.2556
45	9.5953	0.001010	15.251	188.43	2247.7	2436.1	188.44	2394.0	2582.4	0.6386	7.5247	8.1633
50	12.352	0.001012	12.026	209.33	2233.4	2442.7	209.34	2382.0	2591.3	0.7038	7.3710	8.0748
55	15.763	0.001015	9.5639	230.24	2219.1	2449.3	230.26	2369.8	2600.1	0.7680	7.2218	7.9898
60	19.947	0.001017	7.6670	251.16	2204.7	2455.9	251.18	2357.7	2608.8	0.8313	7.0769	7.9082
65	25.043	0.001020	6.1935	272.09	2190.3	2462.4	272.12	2345.4	2617.5	0.8937	6.9360	7.8296
70	31.202	0.001023	5.0396	293.04	2175.8	2468.9	293.07	2333.0	2626.1	0.9551	6.7989	7.7540
75	38.597	0.001026	4.1291	313.99	2161.3	2475.3	314.03	2320.6	2634.6	1.0158	6.6655	7.6812
80	47.416	0.001029	3.4053	334.97	2146.6	2481.6	335.02	2308.0	2643.0	1.0756	6.5355	7.6111
85	57.868	0.001032	2.8261	355.96	2131.9	2487.8	356.02	2295.3	2651.4	1.1346	6.4089	7.5435
90	70.183	0.001036	2.3593	376.97	2117.0	2494.0	377.04	2282.5	2659.6	1.1929	6.2853	7.4782
95	84.609	0.001040	1.9808	398.00	2102.0	2500.1	398.09	2269.6	2667.6	1.2504	6.1647	7.4151
100	101.42	0.001043	1.6720	419.06	2087.0	2506.0	419.17	2256.4	2675.6	1.3072	6.0470	7.3542
105	120.90	0.001047	1.4186	440.15	2071.8	2511.9	440.28	2243.1	2683.4	1.3634	5.9319	7.2952
110	143.38	0.001052	1.2094	461.27	2056.4	2517.7	461.42	2229.7	2691.1	1.4188	5.8193	7.2382
115	169.18	0.001056	1.0360	482.42	2040.9	2523.3	482.59	2216.0	2698.6	1.4737	5.7092	7.1829
120	198.67	0.001060	0.89133	503.60	2025.3	2528.9	503.81	2202.1	2706.0	1.5279	5.6013	7.1292
125	232.23	0.001065	0.77012	524.83	2009.5	2534.3	525.07	2188.1	2713.1	1.5816	5.4956	7.0771
130	270.28	0.001070	0.66808	546.10	1993.4	2539.5	546.38	2173.7	2720.1	1.6346	5.3919	7.0265
135	313.22	0.001075	0.58179	567.41	1977.3	2544.7	567.75	2159.1	2726.9	1.6872	5.2901	6.9773
140	361.53	0.001080	0.50850	588.77	1960.9	2549.6	589.16	2144.3	2733.5	1.7392	5.1901	6.9294
145	415.68	0.001085	0.44600	610.19	1944.2	2554.4	610.64	2129.2	2739.8	1.7908	5.0919	6.8827
150	476.16	0.001091	0.39248	631.66	1927.4	2559.1	632.18	2113.8	2745.9	1.8418	4.9953	6.8371
155	543.49	0.001096	0.34648	653.19	1910.3	2563.5	653.79	2098.0	2751.8	1.8924	4.9002	6.7927
160	618.23	0.001102	0.30680	674.79	1893.0	2567.8	675.47	2082.0	2757.5	1.9426	4.8066	6.7492
165	700.93	0.001108	0.27244	696.46	1875.4	2571.9	697.24	2065.6	2762.8	1.9923	4.7143	6.7067
170	792.18	0.001114	0.24260	718.20	1857.5	2575.7	719.08	2048.8	2767.9	2.0417	4.6233	6.6650
175	892.60	0.001121	0.21659	740.02	1839.4	2579.4	741.02	2031.7	2772.7	2.0906	4.5335	6.6242
180	1002.8	0.001127	0.19384	761.92	1820.9	2582.8	763.05	2014.2	2777.2	2.1392	4.4448	6.5841
185	1123.5	0.001134	0.17390	783.91	1802.1	2586.0	785.19	1996.2	2781.4	2.1875	4.3572	6.5447
190	1255.2	0.001141	0.15636	806.00	1783.0	2589.0	807.43	1977.9	2785.3	2.2355	4.2705	6.5059
195	1398.8	0.001149	0.14089	828.18	1763.6	2591.7	829.78	1959.0	2788.8	2.2831	4.1847	6.4678
200	1554.9	0.001157	0.12721	850.46	1743.7	2594.2	852.26	1939.8	2792.0	2.3305	4.0997	6.4302

TABLE A-4

Saturated water—Temperature table (Concluded)

Temp., $T$ °C	Sat. press., $P_{\text{sat}}$ kPa	Specific volume, $\text{m}^3/\text{kg}$		Internal energy, kJ/kg			Enthalpy, kJ/kg			Entropy, kJ/kg·K		
		Sat. liquid, $v_f$	Sat. vapor, $v_g$	Sat. liquid, $u_f$	Evap., $u_{fg}$	Sat. vapor, $u_g$	Sat. liquid, $h_f$	Evap., $h_{fg}$	Sat. vapor, $h_g$	Sat. liquid, $s_f$	Evap., $s_{fg}$	Sat. vapor, $s_g$
205	1724.3	0.001164	0.11508	872.86	1723.5	2596.4	874.87	1920.0	2794.8	2.3776	4.0154	6.3930
210	1907.7	0.001173	0.10429	895.38	1702.9	2598.3	897.61	1899.7	2797.3	2.4245	3.9318	6.3563
215	2105.9	0.001181	0.094680	918.02	1681.9	2599.9	920.50	1878.8	2799.3	2.4712	3.8489	6.3200
220	2319.6	0.001190	0.086094	940.79	1660.5	2601.3	943.55	1857.4	2801.0	2.5176	3.7664	6.2840
225	2549.7	0.001199	0.078405	963.70	1638.6	2602.3	966.76	1835.4	2802.2	2.5639	3.6844	6.2483
230	2797.1	0.001209	0.071505	986.76	1616.1	2602.9	990.14	1812.8	2802.9	2.6100	3.6028	6.2128
235	3062.6	0.001219	0.065300	1010.0	1593.2	2603.2	1013.7	1789.5	2803.2	2.6560	3.5216	6.1775
240	3347.0	0.001229	0.059707	1033.4	1569.8	2603.1	1037.5	1765.5	2803.0	2.7018	3.4405	6.1424
245	3651.2	0.001240	0.054656	1056.9	1545.7	2602.7	1061.5	1740.8	2802.2	2.7476	3.3596	6.1072
250	3976.2	0.001252	0.050085	1080.7	1521.1	2601.8	1085.7	1715.3	2801.0	2.7933	3.2788	6.0721
255	4322.9	0.001263	0.045941	1104.7	1495.8	2600.5	1110.1	1689.0	2799.1	2.8390	3.1979	6.0369
260	4692.3	0.001276	0.042175	1128.8	1469.9	2598.7	1134.8	1661.8	2796.6	2.8847	3.1169	6.0017
265	5085.3	0.001289	0.038748	1153.3	1443.2	2596.5	1159.8	1633.7	2793.5	2.9304	3.0358	5.9662
270	5503.0	0.001303	0.035622	1177.9	1415.7	2593.7	1185.1	1604.6	2789.7	2.9762	2.9542	5.9305
275	5946.4	0.001317	0.032767	1202.9	1387.4	2590.3	1210.7	1574.5	2785.2	3.0221	2.8723	5.8944
280	6416.6	0.001333	0.030153	1228.2	1358.2	2586.4	1236.7	1543.2	2779.9	3.0681	2.7898	5.8579
285	6914.6	0.001349	0.027756	1253.7	1328.1	2581.8	1263.1	1510.7	2773.7	3.1144	2.7066	5.8210
290	7441.8	0.001366	0.025554	1279.7	1296.9	2576.5	1289.8	1476.9	2766.7	3.1608	2.6225	5.7834
295	7999.0	0.001384	0.023528	1306.0	1264.5	2570.5	1317.1	1441.6	2758.7	3.2076	2.5374	5.7450
300	8587.9	0.001404	0.021659	1332.7	1230.9	2563.6	1344.8	1404.8	2749.6	3.2548	2.4511	5.7059
305	9209.4	0.001425	0.019932	1360.0	1195.9	2555.8	1373.1	1366.3	2739.4	3.3024	2.3633	5.6657
310	9865.0	0.001447	0.018333	1387.7	1159.3	2547.1	1402.0	1325.9	2727.9	3.3506	2.2737	5.6243
315	10,556	0.001472	0.016849	1416.1	1121.1	2537.2	1431.6	1283.4	2715.0	3.3994	2.1821	5.5816
320	11,284	0.001499	0.015470	1445.1	1080.9	2526.0	1462.0	1238.5	2700.6	3.4491	2.0881	5.5372
325	12,051	0.001528	0.014183	1475.0	1038.5	2513.4	1493.4	1191.0	2684.3	3.4998	1.9911	5.4908
330	12,858	0.001560	0.012979	1505.7	993.5	2499.2	1525.8	1140.3	2666.0	3.5516	1.8906	5.4422
335	13,707	0.001597	0.011848	1537.5	945.5	2483.0	1559.4	1086.0	2645.4	3.6050	1.7857	5.3907
340	14,601	0.001638	0.010783	1570.7	893.8	2464.5	1594.6	1027.4	2622.0	3.6602	1.6756	5.3358
345	15,541	0.001685	0.009772	1605.5	837.7	2443.2	1631.7	963.4	2595.1	3.7179	1.5585	5.2765
350	16,529	0.001741	0.008806	1642.4	775.9	2418.3	1671.2	892.7	2563.9	3.7788	1.4326	5.2114
355	17,570	0.001808	0.007872	1682.2	706.4	2388.6	1714.0	812.9	2526.9	3.8442	1.2942	5.1384
360	18,666	0.001895	0.006950	1726.2	625.7	2351.9	1761.5	720.1	2481.6	3.9165	1.1373	5.0537
365	19,822	0.002015	0.006009	1777.2	526.4	2303.6	1817.2	605.5	2422.7	4.0004	0.9489	4.9493
370	21,044	0.002217	0.004953	1844.5	385.6	2230.1	1891.2	443.1	2334.3	4.1119	0.6890	4.8009
373.95	22,064	0.003106	0.003106	2015.7	0	2015.7	2084.3	0	2084.3	4.4070	0	4.4070

Source: Tables A-4 through A-8 are generated using the Engineering Equation Solver (EES) software developed by S. A. Klein and F. L. Alvarado. The routine used in calculations is the highly accurate Steam\_IAPWS, which incorporates the 1995 Formulation for the Thermodynamic Properties of Ordinary Water Substance for General and Scientific Use, issued by The International Association for the Properties of Water and Steam (IAPWS). This formulation replaces the 1984 formulation of Haar, Gallagher, and Kell (NBS/NRC Steam Tables, Hemisphere Publishing Co., 1984), which is also available in EES as the routine STEAM. The new formulation is based on the correlations of Saul and Wagner (J. Phys. Chem. Ref. Data, 16, 893, 1987) with modifications to adjust to the International Temperature Scale of 1990. The modifications are described by Wagner and Pruss (J. Phys. Chem. Ref. Data, 22, 783, 1993). The properties of ice are based on Hyland and Wexler, "Formulations for the Thermodynamic Properties of the Saturated Phases of H<sub>2</sub>O from 173.15 K to 473.15 K," ASHRAE Trans., Part 2A, Paper 2793, 1983.

TABLE A-5

Saturated water—Pressure table (Concluded)

Press., P kPa	Sat. temp., $T_{sat}$ °C	Specific volume, $m^3/kg$		Internal energy, kJ/kg			Enthalpy, kJ/kg			Entropy, kJ/kg·K		
		Sat. liquid, $v_f$	Sat. vapor, $v_g$	Sat. liquid, $u_f$	Evap., $u_{fg}$	Sat. vapor, $u_g$	Sat. liquid, $h_f$	Evap., $h_{fg}$	Sat. vapor, $h_g$	Sat. liquid, $s_f$	Evap., $s_{fg}$	Sat. vapor, $s_g$
800	170.41	0.001115	0.24035	719.97	1856.1	2576.0	720.87	2047.5	2768.3	2.0457	4.6160	6.6616
850	172.94	0.001118	0.22690	731.00	1846.9	2577.9	731.95	2038.8	2770.8	2.0705	4.5705	6.6409
900	175.35	0.001121	0.21489	741.55	1838.1	2579.6	742.56	2030.5	2773.0	2.0941	4.5273	6.6213
950	177.66	0.001124	0.20411	751.67	1829.6	2581.3	752.74	2022.4	2775.2	2.1166	4.4862	6.6027
1000	179.88	0.001127	0.19436	761.39	1821.4	2582.8	762.51	2014.6	2777.1	2.1381	4.4470	6.5850
1100	184.06	0.001133	0.17745	779.78	1805.7	2585.5	781.03	1999.6	2780.7	2.1785	4.3735	6.5520
1200	187.96	0.001138	0.16326	796.96	1790.9	2587.8	798.33	1985.4	2783.8	2.2159	4.3058	6.5217
1300	191.60	0.001144	0.15119	813.10	1776.8	2589.9	814.59	1971.9	2786.5	2.2508	4.2428	6.4936
1400	195.04	0.001149	0.14078	828.35	1763.4	2591.8	829.96	1958.9	2788.9	2.2835	4.1840	6.4675
1500	198.29	0.001154	0.13171	842.82	1750.6	2593.4	844.55	1946.4	2791.0	2.3143	4.1287	6.4430
1750	205.72	0.001166	0.11344	876.12	1720.6	2596.7	878.16	1917.1	2795.2	2.3844	4.0033	6.3877
2000	212.38	0.001177	0.099587	906.12	1693.0	2599.1	908.47	1889.8	2798.3	2.4467	3.8923	6.3390
2250	218.41	0.001187	0.088717	933.54	1667.3	2600.9	936.21	1864.3	2800.5	2.5029	3.7926	6.2954
2500	223.95	0.001197	0.079952	958.87	1643.2	2602.1	961.87	1840.1	2801.9	2.5542	3.7016	6.2558
3000	233.85	0.001217	0.066667	1004.6	1598.5	2603.2	1008.3	1794.9	2803.2	2.6454	3.5402	6.1856
3500	242.56	0.001235	0.057061	1045.4	1557.6	2603.0	1049.7	1753.0	2802.7	2.7253	3.3991	6.1244
4000	250.35	0.001252	0.049779	1082.4	1519.3	2601.7	1087.4	1713.5	2800.8	2.7966	3.2731	6.0696
5000	263.94	0.001286	0.039448	1148.1	1448.9	2597.0	1154.5	1639.7	2794.2	2.9207	3.0530	5.9737
6000	275.59	0.001319	0.032449	1205.8	1384.1	2589.9	1213.8	1570.9	2784.6	3.0275	2.8627	5.8902
7000	285.83	0.001352	0.027378	1258.0	1323.0	2581.0	1267.5	1505.2	2772.6	3.1220	2.6927	5.8148
8000	295.01	0.001384	0.023525	1306.0	1264.5	2570.5	1317.1	1441.6	2758.7	3.2077	2.5373	5.7450
9000	303.35	0.001418	0.020489	1350.9	1207.6	2558.5	1363.7	1379.3	2742.9	3.2866	2.3925	5.6791
10,000	311.00	0.001452	0.018028	1393.3	1151.8	2545.2	1407.8	1317.6	2725.5	3.3603	2.2556	5.6159
11,000	318.08	0.001488	0.015988	1433.9	1096.6	2530.4	1450.2	1256.1	2706.3	3.4299	2.1245	5.5544
12,000	324.68	0.001526	0.014264	1473.0	1041.3	2514.3	1491.3	1194.1	2685.4	3.4964	1.9975	5.4939
13,000	330.85	0.001566	0.012781	1511.0	985.5	2496.6	1531.4	1131.3	2662.7	3.5606	1.8730	5.4336
14,000	336.67	0.001610	0.011487	1548.4	928.7	2477.1	1571.0	1067.0	2637.9	3.6232	1.7497	5.3728
15,000	342.16	0.001657	0.010341	1585.5	870.3	2455.7	1610.3	1000.5	2610.8	3.6848	1.6261	5.3108
16,000	347.36	0.001710	0.009312	1622.6	809.4	2432.0	1649.9	931.1	2581.0	3.7461	1.5005	5.2466
17,000	352.29	0.001770	0.008374	1660.2	745.1	2405.4	1690.3	857.4	2547.7	3.8082	1.3709	5.1791
18,000	356.99	0.001840	0.007504	1699.1	675.9	2375.0	1732.2	777.8	2510.0	3.8720	1.2343	5.1064
19,000	361.47	0.001926	0.006677	1740.3	598.9	2339.2	1776.8	689.2	2466.0	3.9396	1.0860	5.0256
20,000	365.75	0.002038	0.005862	1785.8	509.0	2294.8	1826.6	585.5	2412.1	4.0146	0.9164	4.9310
21,000	369.83	0.002207	0.004994	1841.6	391.9	2233.5	1888.0	450.4	2338.4	4.1071	0.7005	4.8076
22,000	373.71	0.002703	0.003644	1951.7	140.8	2092.4	2011.1	161.5	2172.6	4.2942	0.2496	4.5439
22,064	373.95	0.003106	0.003106	2015.7	0	2015.7	2084.3	0	2084.3	4.4070	0	4.4070

TABLE A-6

Superheated water (Continued)

<i>T</i> °C	<i>v</i> m <sup>3</sup> /kg	<i>u</i> kJ/kg	<i>h</i> kJ/kg	<i>s</i> kJ/kg·K	<i>v</i> m <sup>3</sup> /kg	<i>u</i> kJ/kg	<i>h</i> kJ/kg	<i>s</i> kJ/kg·K	<i>v</i> m <sup>3</sup> /kg	<i>u</i> kJ/kg	<i>h</i> kJ/kg	<i>s</i> kJ/kg·K
P = 4.0 MPa (250.35°C)				P = 4.5 MPa (257.44°C)				P = 5.0 MPa (263.94°C)				
Sat.	0.04978	2601.7	2800.8	6.0696	0.04406	2599.7	2798.0	6.0198	0.03945	2597.0	2794.2	5.9737
275	0.05461	2668.9	2887.3	6.2312	0.04733	2651.4	2864.4	6.1429	0.04144	2632.3	2839.5	6.0571
300	0.05887	2726.2	2961.7	6.3639	0.05138	2713.0	2944.2	6.2854	0.04535	2699.0	2925.7	6.2111
350	0.06647	2827.4	3093.3	6.5843	0.05842	2818.6	3081.5	6.5153	0.05197	2809.5	3069.3	6.4516
400	0.07343	2920.8	3214.5	6.7714	0.06477	2914.2	3205.7	6.7071	0.05784	2907.5	3196.7	6.6483
450	0.08004	3011.0	3331.2	6.9386	0.07076	3005.8	3324.2	6.8770	0.06332	3000.6	3317.2	6.8210
500	0.08644	3100.3	3446.0	7.0922	0.07652	3096.0	3440.4	7.0323	0.06858	3091.8	3434.7	6.9781
600	0.09886	3279.4	3674.9	7.3706	0.08766	3276.4	3670.9	7.3127	0.07870	3273.3	3666.9	7.2605
700	0.11098	3462.4	3906.3	7.6214	0.09850	3460.0	3903.3	7.5647	0.08852	3457.7	3900.3	7.5136
800	0.12292	3650.6	4142.3	7.8523	0.10916	3648.8	4140.0	7.7962	0.09816	3646.9	4137.7	7.7458
900	0.13476	3844.8	4383.9	8.0675	0.11972	3843.3	4382.1	8.0118	0.10769	3841.8	4380.2	7.9619
1000	0.14653	4045.1	4631.2	8.2698	0.13020	4043.9	4629.8	8.2144	0.11715	4042.6	4628.3	8.1648
1100	0.15824	4251.4	4884.4	8.4612	0.14064	4250.4	4883.2	8.4060	0.12655	4249.3	4882.1	8.3566
1200	0.16992	4463.5	5143.2	8.6430	0.15103	4462.6	5142.2	8.5880	0.13592	4461.6	5141.3	8.5388
1300	0.18157	4680.9	5407.2	8.8164	0.16140	4680.1	5406.5	8.7616	0.14527	4679.3	5405.7	8.7124
P = 6.0 MPa (275.59°C)				P = 7.0 MPa (285.83°C)				P = 8.0 MPa (295.01°C)				
Sat.	0.03245	2589.9	2784.6	5.8902	0.027378	2581.0	2772.6	5.8148	0.023525	2570.5	2758.7	5.7450
300	0.03619	2668.4	2885.6	6.0703	0.029492	2633.5	2839.9	5.9337	0.024279	2592.3	2786.5	5.7937
350	0.04225	2790.4	3043.9	6.3357	0.035262	2770.1	3016.9	6.2305	0.029975	2748.3	2988.1	6.1321
400	0.04742	2893.7	3178.3	6.5432	0.039958	2879.5	3159.2	6.4502	0.034344	2864.6	3139.4	6.3658
450	0.05217	2989.9	3302.9	6.7219	0.044187	2979.0	3288.3	6.6353	0.038194	2967.8	3273.3	6.5579
500	0.05667	3083.1	3423.1	6.8826	0.048157	3074.3	3411.4	6.8000	0.041767	3065.4	3399.5	6.7266
550	0.06102	3175.2	3541.3	7.0308	0.051966	3167.9	3531.6	6.9507	0.045172	3160.5	3521.8	6.8800
600	0.06527	3267.2	3658.8	7.1693	0.055665	3261.0	3650.6	7.0910	0.048463	3254.7	3642.4	7.0221
700	0.07355	3453.0	3894.3	7.4247	0.062850	3448.3	3888.3	7.3487	0.054829	3443.6	3882.2	7.2822
800	0.08165	3643.2	4133.1	7.6582	0.069856	3639.5	4128.5	7.5836	0.061011	3635.7	4123.8	7.5185
900	0.08964	3838.8	4376.6	7.8751	0.076750	3835.7	4373.0	7.8014	0.067082	3832.7	4369.3	7.7372
1000	0.09756	4040.1	4625.4	8.0786	0.083571	4037.5	4622.5	8.0055	0.073079	4035.0	4619.6	7.9419
1100	0.10543	4247.1	4879.7	8.2709	0.090341	4245.0	4877.4	8.1982	0.079025	4242.8	4875.0	8.1350
1200	0.11326	4459.8	5139.4	8.4534	0.097075	4457.9	5137.4	8.3810	0.084934	4456.1	5135.5	8.3181
1300	0.12107	4677.7	5404.1	8.6273	0.103781	4676.1	5402.6	8.5551	0.090817	4674.5	5401.0	8.4925
P = 9.0 MPa (303.35°C)				P = 10.0 MPa (311.00°C)				P = 12.5 MPa (327.81°C)				
Sat.	0.020489	2558.5	2742.9	5.6791	0.018028	2545.2	2725.5	5.6159	0.013496	2505.6	2674.3	5.4638
325	0.023284	2647.6	2857.1	5.8738	0.019877	2611.6	2810.3	5.7596	0.016138	2624.9	2826.6	5.7130
350	0.025816	2725.0	2957.3	6.0380	0.022440	2699.6	2924.0	5.9460	0.020030	2789.6	3040.0	6.0433
400	0.029960	2849.2	3118.8	6.2876	0.026436	2833.1	3097.5	6.2141	0.023019	2913.7	3201.5	6.2749
450	0.033524	2956.3	3258.0	6.4872	0.029782	2944.5	3242.4	6.4219	0.025630	3023.2	3343.6	6.4651
500	0.036793	3056.3	3387.4	6.6603	0.032811	3047.0	3375.1	6.5995	0.028033	3126.1	3476.5	6.6317
550	0.039885	3153.0	3512.0	6.8164	0.035655	3145.4	3502.0	6.7585	0.030306	3225.8	3604.6	6.7828
600	0.042861	3248.4	3634.1	6.9605	0.038378	3242.0	3625.8	6.9045	0.032491	3324.1	3730.2	6.9227
650	0.045755	3343.4	3755.2	7.0954	0.041018	3338.0	3748.1	7.0408	0.034612	3422.0	3854.6	7.0540
700	0.048589	3438.8	3876.1	7.2229	0.043597	3434.0	3870.0	7.1693	0.036724	3518.8	4102.8	7.2967
800	0.054132	3632.0	4119.2	7.4606	0.048629	3628.2	4114.5	7.4085	0.042720	3818.9	4352.9	7.5195
900	0.059562	3829.6	4365.7	7.6802	0.053547	3826.5	4362.0	7.6290	0.046641	4023.5	4606.5	7.7269
1000	0.064919	4032.4	4616.7	7.8855	0.058391	4029.9	4613.8	7.8349	0.050510	4233.1	4864.5	7.9220
1100	0.070224	4240.7	4872.7	8.0791	0.063183	4238.5	4870.3	8.0289	0.054342	4447.7	5127.0	8.1065
1200	0.075492	4454.2	5133.6	8.2625	0.067938	4452.4	5131.7	8.2126	0.058147	4667.3	5394.1	8.2819
1300	0.080733	4672.9	5399.5	8.4371	0.072667	4671.3	5398.0	8.3874				

TABLE A-18

Ideal-gas properties of nitrogen, N<sub>2</sub>

$T$ K	$\bar{h}$ kJ/kmol	$\bar{u}$ kJ/kmol	$\bar{s}^\circ$ kJ/kmol·K	$T$ K	$\bar{h}$ kJ/kmol	$\bar{u}$ kJ/kmol	$\bar{s}^\circ$ kJ/kmol·K
0	0	0	0	600	17,563	12,574	212.066
220	6,391	4,562	182.639	610	17,864	12,792	212.564
230	6,683	4,770	183.938	620	18,166	13,011	213.055
240	6,975	4,979	185.180	630	18,468	13,230	213.541
250	7,266	5,188	186.370	640	18,772	13,450	214.018
260	7,558	5,396	187.514	650	19,075	13,671	214.489
270	7,849	5,604	188.614	660	19,380	13,892	214.954
280	8,141	5,813	189.673	670	19,685	14,114	215.413
290	8,432	6,021	190.695	680	19,991	14,337	215.866
298	8,669	6,190	191.502	690	20,297	14,560	216.314
300	8,723	6,229	191.682	700	20,604	14,784	216.756
310	9,014	6,437	192.638	710	20,912	15,008	217.192
320	9,306	6,645	193.562	720	21,220	15,234	217.624
330	9,597	6,853	194.459	730	21,529	15,460	218.059
340	9,888	7,061	195.328	740	21,839	15,686	218.472
350	10,180	7,270	196.173	750	22,149	15,913	218.889
360	10,471	7,478	196.995	760	22,460	16,141	219.301
370	10,763	7,687	197.794	770	22,772	16,370	219.709
380	11,055	7,895	198.572	780	23,085	16,599	220.113
390	11,347	8,104	199.331	790	23,398	16,830	220.512
400	11,640	8,314	200.071	800	23,714	17,061	220.907
410	11,932	8,523	200.794	810	24,027	17,292	221.298
420	12,225	8,733	201.499	820	24,342	17,524	221.684
430	12,518	8,943	202.189	830	24,658	17,757	222.067
440	12,811	9,153	202.863	840	24,974	17,990	222.447
450	13,105	9,363	203.523	850	25,292	18,224	222.822
460	13,399	9,574	204.170	860	25,610	18,459	223.194
470	13,693	9,786	204.803	870	25,928	18,695	223.562
480	13,988	9,997	205.424	880	26,248	18,931	223.927
490	14,285	10,210	206.033	890	26,568	19,168	224.288
500	14,581	10,423	206.630	900	26,890	19,407	224.647
510	14,876	10,635	207.216	910	27,210	19,644	225.002
520	15,172	10,848	207.792	920	27,532	19,883	225.353
530	15,469	11,062	208.358	930	27,854	20,122	225.701
540	15,766	11,277	208.914	940	28,178	20,362	226.047
550	16,064	11,492	209.461	950	28,501	20,603	226.389
560	16,363	11,707	209.999	960	28,826	20,844	226.728
570	16,662	11,923	210.528	970	29,151	21,086	227.064
580	16,962	12,139	211.049	980	29,476	21,328	227.398
590	17,262	12,356	211.562	990	29,803	21,571	227.728

TABLE A-18

Ideal-gas properties of nitrogen, N<sub>2</sub> (Concluded)

<i>T</i> K	$\bar{h}$ kJ/kmol	$\bar{u}$ kJ/kmol	$\bar{s}^\circ$ kJ/kmol·K	<i>T</i> K	$\bar{h}$ kJ/kmol	$\bar{u}$ kJ/kmol	$\bar{s}^\circ$ kJ/kmol·K
1000	30,129	21,815	228.057	1760	56,227	41,594	247.396
1020	30,784	22,304	228.706	1780	56,938	42,139	247.798
1040	31,442	22,795	229.344	1800	57,651	42,685	248.195
1060	32,101	23,288	229.973	1820	58,363	43,231	248.589
1080	32,762	23,782	230.591	1840	59,075	43,777	248.979
1100	33,426	24,280	231.199	1860	59,790	44,324	249.365
1120	34,092	24,780	231.799	1880	60,504	44,873	249.748
1140	34,760	25,282	232.391	1900	61,220	45,423	250.128
1160	35,430	25,786	232.973	1920	61,936	45,973	250.502
1180	36,104	26,291	233.549	1940	62,654	46,524	250.874
1200	36,777	26,799	234.115	1960	63,381	47,075	251.242
1220	37,452	27,308	234.673	1980	64,090	47,627	251.607
1240	38,129	27,819	235.223	2000	64,810	48,181	251.969
1260	38,807	28,331	235.766	2050	66,612	49,567	252.858
1280	39,488	28,845	236.302	2100	68,417	50,957	253.726
1300	40,170	29,361	236.831	2150	70,226	52,351	254.578
1320	40,853	29,378	237.353	2200	72,040	53,749	255.412
1340	41,539	30,398	237.867	2250	73,856	55,149	256.227
1360	42,227	30,919	238.376	2300	75,676	56,553	257.027
1380	42,915	31,441	238.878	2350	77,496	57,958	257.810
1400	43,605	31,964	239.375	2400	79,320	59,366	258.580
1420	44,295	32,489	239.865	2450	81,149	60,779	259.332
1440	44,988	33,014	240.350	2500	82,981	62,195	260.073
1460	45,682	33,543	240.827	2550	84,814	63,613	260.799
1480	46,377	34,071	241.301	2600	86,650	65,033	261.512
1500	47,073	34,601	241.768	2650	88,488	66,455	262.213
1520	47,771	35,133	242.228	2700	90,328	67,880	262.902
1540	48,470	35,665	242.685	2750	92,171	69,306	263.577
1560	49,168	36,197	243.137	2800	94,014	70,734	264.241
1580	49,869	36,732	243.585	2850	95,859	72,163	264.895
1600	50,571	37,268	244.028	2900	97,705	73,593	265.538
1620	51,275	37,806	244.464	2950	99,556	75,028	266.170
1640	51,980	38,344	244.896	3000	101,407	76,464	266.793
1660	52,686	38,884	245.324	3050	103,260	77,902	267.404
1680	53,393	39,424	245.747	3100	105,115	79,341	268.007
1700	54,099	39,965	246.166	3150	106,972	80,782	268.601
1720	54,807	40,507	246.580	3200	108,830	82,224	269.186
1740	55,516	41,049	246.990	3250	110,690	83,668	269.763

Source: Tables A-18 through A-25 are adapted from Kenneth Wark, *Thermodynamics*, 4th ed. (New York: McGraw-Hill, 1983), pp. 787-98. Originally published in JANAF, *Thermochemical Tables*, NSRDS-NBS-37, 1971.



TABLE A-19

Ideal-gas properties of oxygen,  $O_2$ 

$T$ K	$\bar{h}$ kJ/kmol	$\bar{u}$ kJ/kmol	$\bar{s}^\circ$ kJ/kmol·K	$T$ K	$\bar{h}$ kJ/kmol	$\bar{u}$ kJ/kmol	$\bar{s}^\circ$ kJ/kmol·K
0	0	0	0	600	17,929	12,940	226.346
220	6,404	4,575	196.171	610	18,250	13,178	226.877
230	6,694	4,782	197.461	620	18,572	13,417	227.400
240	6,984	4,989	198.696	630	18,895	13,657	227.918
250	7,275	5,197	199.885	640	19,219	13,898	228.429
260	7,566	5,405	201.027	650	19,544	14,140	228.932
270	7,858	5,613	202.128	660	19,870	14,383	229.430
280	8,150	5,822	203.191	670	20,197	14,626	229.920
290	8,443	6,032	204.218	680	20,524	14,871	230.405
298	8,682	6,203	205.033	690	20,854	15,116	230.885
300	8,736	6,242	205.213	700	21,184	15,364	231.358
310	9,030	6,453	206.177	710	21,514	15,611	231.827
320	9,325	6,664	207.112	720	21,845	15,859	232.291
330	9,620	6,877	208.020	730	22,177	16,107	232.748
340	9,916	7,090	208.904	740	22,510	16,357	233.201
350	10,213	7,303	209.765	750	22,844	16,607	233.649
360	10,511	7,518	210.604	760	23,178	16,859	234.091
370	10,809	7,733	211.423	770	23,513	17,111	234.528
380	11,109	7,949	212.222	780	23,850	17,364	234.960
390	11,409	8,166	213.002	790	24,186	17,618	235.387
400	11,711	8,384	213.765	800	24,523	17,872	235.810
410	12,012	8,603	214.510	810	24,861	18,126	236.230
420	12,314	8,822	215.241	820	25,199	18,382	236.644
430	12,618	9,043	215.955	830	25,537	18,637	237.055
440	12,923	9,264	216.656	840	25,877	18,893	237.462
450	13,228	9,487	217.342	850	26,218	19,150	237.864
460	13,525	9,710	218.016	860	26,559	19,408	238.264
470	13,842	9,935	218.676	870	26,899	19,666	238.660
480	14,151	10,160	219.326	880	27,242	19,925	239.051
490	14,460	10,386	219.963	890	27,584	20,185	239.439
500	14,770	10,614	220.589	900	27,928	20,445	239.823
510	15,082	10,842	221.206	910	28,272	20,706	240.203
520	15,395	11,071	221.812	920	28,616	20,967	240.580
530	15,708	11,301	222.409	930	28,960	21,228	240.953
540	16,022	11,533	222.997	940	29,306	21,491	241.323
550	16,338	11,765	223.576	950	29,652	21,754	241.689
560	16,654	11,998	224.146	960	29,999	22,017	242.052
570	16,971	12,232	224.708	970	30,345	22,280	242.411
580	17,290	12,467	225.262	980	30,692	22,544	242.768
590	17,609	12,703	225.808	990	31,041	22,809	242.120

TABLE A-19

Ideal-gas properties of oxygen, O<sub>2</sub> (Concluded)

$T$ K	$\bar{h}$ kJ/kmol	$\bar{u}$ kJ/kmol	$\bar{s}^\circ$ kJ/kmol·K	$T$ K	$\bar{h}$ kJ/kmol	$\bar{u}$ kJ/kmol	$\bar{s}^\circ$ kJ/kmol·K
1000	31,389	23,075	243.471	1760	58,880	44,247	263.861
1020	32,088	23,607	244.164	1780	59,624	44,825	264.283
1040	32,789	24,142	244.844	1800	60,371	45,405	264.701
1060	33,490	24,677	245.513	1820	61,118	45,986	265.113
1080	34,194	25,214	246.171	1840	61,866	46,568	265.521
1100	34,899	25,753	246.818	1860	62,616	47,151	265.925
1120	35,606	26,294	247.454	1880	63,365	47,734	266.326
1140	36,314	26,836	248.081	1900	64,116	48,319	266.722
1160	37,023	27,379	248.698	1920	64,868	48,904	267.115
1180	37,734	27,923	249.307	1940	65,620	49,490	267.505
1200	38,447	28,469	249.906	1960	66,374	50,078	267.891
1220	39,162	29,018	250.497	1980	67,127	50,665	268.275
1240	39,877	29,568	251.079	2000	67,881	51,253	268.655
1260	40,594	30,118	251.653	2050	69,772	52,727	269.588
1280	41,312	30,670	252.219	2100	71,668	54,208	270.504
1300	42,033	31,224	252.776	2150	73,573	55,697	271.399
1320	42,753	31,778	253.325	2200	75,484	57,192	272.278
1340	43,475	32,334	253.868	2250	77,397	58,690	273.136
1360	44,198	32,891	254.404	2300	79,316	60,193	273.891
1380	44,923	33,449	254.932	2350	81,243	61,704	274.809
1400	45,648	34,008	255.454	2400	83,174	63,219	275.625
1420	46,374	34,567	255.968	2450	85,112	64,742	276.424
1440	47,102	35,129	256.475	2500	87,057	66,271	277.207
1460	47,831	35,692	256.978	2550	89,004	67,802	277.979
1480	48,561	36,256	257.474	2600	90,956	69,339	278.738
1500	49,292	36,821	257.965	2650	92,916	70,883	279.485
1520	50,024	37,387	258.450	2700	94,881	72,433	280.219
1540	50,756	37,952	258.928	2750	96,852	73,987	280.942
1560	51,490	38,520	259.402	2800	98,826	75,546	281.654
1580	52,224	39,088	259.870	2850	100,808	77,112	282.357
1600	52,961	39,658	260.333	2900	102,793	78,682	283.048
1620	53,696	40,227	260.791	2950	104,785	80,258	283.728
1640	54,434	40,799	261.242	3000	106,780	81,837	284.399
1660	55,172	41,370	261.690	3050	108,778	83,419	285.060
1680	55,912	41,944	262.132	3100	110,784	85,009	285.713
1700	56,652	42,517	262.571	3150	112,795	86,601	286.355
1720	57,394	43,093	263.005	3200	114,809	88,203	286.989
1740	58,136	43,669	263.435	3250	116,827	89,804	287.614

TABLE A-20

Ideal-gas properties of carbon dioxide, CO<sub>2</sub>

$T$ K	$\bar{h}$ kJ/kmol	$\bar{u}$ kJ/kmol	$\bar{s}^\circ$ kJ/kmol·K	$T$ K	$\bar{h}$ kJ/kmol	$\bar{u}$ kJ/kmol	$\bar{s}^\circ$ kJ/kmol·K
0	0	0	0	600	22,280	17,291	243.199
220	6,601	4,772	202.966	610	22,754	17,683	243.983
230	6,938	5,026	204.464	620	23,231	18,076	244.758
240	7,280	5,285	205.920	630	23,709	18,471	245.524
250	7,627	5,548	207.337	640	24,190	18,869	246.282
260	7,979	5,817	208.717	650	24,674	19,270	247.032
270	8,335	6,091	210.062	660	25,160	19,672	247.773
280	8,697	6,369	211.376	670	25,648	20,078	248.507
290	9,063	6,651	212.660	680	26,138	20,484	249.233
298	9,364	6,885	213.685	690	26,631	20,894	249.952
300	9,431	6,939	213.915	700	27,125	21,305	250.663
310	9,807	7,230	215.146	710	27,622	21,719	251.368
320	10,186	7,526	216.351	720	28,121	22,134	252.065
330	10,570	7,826	217.534	730	28,622	22,522	252.755
340	10,959	8,131	218.694	740	29,124	22,972	253.439
350	11,351	8,439	219.831	750	29,629	23,393	254.117
360	11,748	8,752	220.948	760	30,135	23,817	254.787
370	12,148	9,068	222.044	770	30,644	24,242	255.452
380	12,552	9,392	223.122	780	31,154	24,669	256.110
390	12,960	9,718	224.182	790	31,665	25,097	256.762
400	13,372	10,046	225.225	800	32,179	25,527	257.408
410	13,787	10,378	226.250	810	32,694	25,959	258.048
420	14,206	10,714	227.258	820	33,212	26,394	258.682
430	14,628	11,053	228.252	830	33,730	26,829	259.311
440	15,054	11,393	229.230	840	34,251	27,267	259.934
450	15,483	11,742	230.194	850	34,773	27,706	260.551
460	15,916	12,091	231.144	860	35,296	28,125	261.164
470	16,351	12,444	232.080	870	35,821	28,588	261.770
480	16,791	12,800	233.004	880	36,347	29,031	262.371
490	17,232	13,158	233.916	890	36,876	29,476	262.968
500	17,678	13,521	234.814	900	37,405	29,922	263.559
510	18,126	13,885	235.700	910	37,935	30,369	264.146
520	18,576	14,253	236.575	920	38,467	30,818	264.728
530	19,029	14,622	237.439	930	39,000	31,268	265.304
540	19,485	14,996	238.292	940	39,535	31,719	265.877
550	19,945	15,372	239.135	950	40,070	32,171	266.444
560	20,407	15,751	239.962	960	40,607	32,625	267.007
570	20,870	16,131	240.789	970	41,145	33,081	267.566
580	21,337	16,515	241.602	980	41,685	33,537	268.119
590	21,807	16,902	242.405	990	42,226	33,995	268.670

TABLE A-20

Ideal-gas properties of carbon dioxide, CO<sub>2</sub> (Concluded)

$T$ K	$\bar{h}$ kJ/kmol	$\bar{u}$ kJ/kmol	$\bar{s}^\circ$ kJ/kmol·K	$T$ K	$\bar{h}$ kJ/kmol	$\bar{u}$ kJ/kmol	$\bar{s}^\circ$ kJ/kmol·K
1000	42,769	34,455	269.215	1760	86,420	71,787	301.543
1020	43,859	35,378	270.293	1780	87,612	72,812	302.217
1040	44,953	36,306	271.354	1800	88,806	73,840	302.884
1060	46,051	37,238	272.400	1820	90,000	74,868	303.544
1080	47,153	38,174	273.430	1840	91,196	75,897	304.198
1100	48,258	39,112	274.445	1860	92,394	76,929	304.845
1120	49,369	40,057	275.444	1880	93,593	77,962	305.487
1140	50,484	41,006	276.430	1900	94,793	78,996	306.122
1160	51,602	41,957	277.403	1920	95,995	80,031	306.751
1180	52,724	42,913	278.361	1940	97,197	81,067	307.374
1200	53,848	43,871	297.307	1960	98,401	82,105	307.992
1220	54,977	44,834	280.238	1980	99,606	83,144	308.604
1240	56,108	45,799	281.158	2000	100,804	84,185	309.210
1260	57,244	46,768	282.066	2050	103,835	86,791	310.701
1280	58,381	47,739	282.962	2100	106,864	89,404	312.160
1300	59,522	48,713	283.847	2150	109,898	92,023	313.589
1320	60,666	49,691	284.722	2200	112,939	94,648	314.988
1340	61,813	50,672	285.586	2250	115,984	97,277	316.356
1360	62,963	51,656	286.439	2300	119,035	99,912	317.695
1380	64,116	52,643	287.283	2350	122,091	102,552	319.011
1400	65,271	53,631	288.106	2400	125,152	105,197	320.302
1420	66,427	54,621	288.934	2450	128,219	107,849	321.566
1440	67,586	55,614	289.743	2500	131,290	110,504	322.808
1460	68,748	56,609	290.542	2550	134,368	113,166	324.026
1480	66,911	57,606	291.333	2600	137,449	115,832	325.222
1500	71,078	58,606	292.114	2650	140,533	118,500	326.396
1520	72,246	59,609	292.888	2700	143,620	121,172	327.549
1540	73,417	60,613	292.654	2750	146,713	123,849	328.684
1560	74,590	61,620	294.411	2800	149,808	126,528	329.800
1580	76,767	62,630	295.161	2850	152,908	129,212	330.896
1600	76,944	63,741	295.901	2900	156,009	131,898	331.975
1620	78,123	64,653	296.632	2950	159,117	134,589	333.037
1640	79,303	65,668	297.356	3000	162,226	137,283	334.084
1660	80,486	66,592	298.072	3050	165,341	139,982	335.114
1680	81,670	67,702	298.781	3100	168,456	142,681	336.126
1700	82,856	68,721	299.482	3150	171,576	145,385	337.124
1720	84,043	69,742	300.177	3200	174,695	148,089	338.109
1740	85,231	70,764	300.863	3250	177,822	150,801	339.069

TABLE A-26

Enthalpy of formation, Gibbs function of formation, and absolute entropy at 25°C, 1 atm

Substance	Formula	$\bar{h}_f^\circ$ kJ/kmol	$\bar{g}_f^\circ$ kJ/kmol	$\bar{s}^\circ$ kJ/kmol·K
Carbon	C(s)	0	0	5.74
Hydrogen	H <sub>2</sub> (g)	0	0	130.68
Nitrogen	N <sub>2</sub> (g)	0	0	191.61
Oxygen	O <sub>2</sub> (g)	0	0	205.04
Carbon monoxide	CO(g)	-110,530	-137,150	197.65
Carbon dioxide	CO <sub>2</sub> (g)	-393,520	-394,360	213.80
Water vapor	H <sub>2</sub> O(g)	-241,820	-228,590	188.83
Water	H <sub>2</sub> O(l)	-285,830	-237,180	69.92
Hydrogen peroxide	H <sub>2</sub> O <sub>2</sub> (g)	-136,310	-105,600	232.63
Ammonia	NH <sub>3</sub> (g)	-46,190	-16,590	192.33
Methane	CH <sub>4</sub> (g)	-74,850	-50,790	186.16
Acetylene	C <sub>2</sub> H <sub>2</sub> (g)	+226,730	+209,170	200.85
Ethylene	C <sub>2</sub> H <sub>4</sub> (g)	+52,280	+68,120	219.83
Ethane	C <sub>2</sub> H <sub>6</sub> (g)	-84,680	-32,890	229.49
Propylene	C <sub>3</sub> H <sub>6</sub> (g)	+20,410	+62,720	266.94
Propane	C <sub>3</sub> H <sub>8</sub> (g)	-103,850	-23,490	269.91
n-Butane	C <sub>4</sub> H <sub>10</sub> (g)	-126,150	-15,710	310.12
n-Octane	C <sub>8</sub> H <sub>18</sub> (g)	-208,450	+16,530	466.73
n-Octane	C <sub>8</sub> H <sub>18</sub> (l)	-249,950	+6,610	360.79
n-Dodecane	C <sub>12</sub> H <sub>26</sub> (g)	-291,010	+50,150	622.83
Benzene	C <sub>6</sub> H <sub>6</sub> (g)	+82,930	+129,660	269.20
Methyl alcohol	CH <sub>3</sub> OH(g)	-200,670	-162,000	239.70
Methyl alcohol	CH <sub>3</sub> OH(l)	-238,660	-166,360	126.80
Ethyl alcohol	C <sub>2</sub> H <sub>5</sub> OH(g)	-235,310	-168,570	282.59
Ethyl alcohol	C <sub>2</sub> H <sub>5</sub> OH(l)	-277,690	-174,890	160.70
Oxygen	O(g)	+249,190	+231,770	161.06
Hydrogen	H(g)	+218,000	+203,290	114.72
Nitrogen	N(g)	+472,650	+455,510	153.30
Hydroxyl	OH(g)	+39,460	+34,280	183.70

Source: From JANAF, *Thermochemical Tables* (Midland, MI: Dow Chemical Co., 1971); *Selected Values of Chemical Thermodynamic Properties*, NBS Technical Note 270-3, 1968; and *API Research Project 44* (Carnegie Press, 1953).